

September 1989

Order Number: 311461-002



iPSC[®]/2 HARDWARE INSTALLATION MANUAL



intel[®] Corporation

Copyright ©1989 by Intel Scientific Computers, Beaverton, Oregon. All rights reserved. No part of this work may be reproduced or copied in any form or by any means...graphic, electronic, or mechanical including photocopying, taping, or information storage and retrieval systems...without the express written consent of Intel Corporation. The information in this document is subject to change without notice.

Intel Corporation make no warranty of any kind with regard to this material, including, but not limited to, the implied warranties of merchantability and fitness for a particular purpose. Intel Corporation assumes no responsibility for any errors that may appear in this document. Intel Corporation makes no commitment to update or to keep current the information contained in this document.

Intel Corporation assumes no responsibility for the use of any circuitry other than circuitry embodied in an Intel product. No other circuit patent licenses are implied.

Intel software products are copyrighted by and shall remain the property of Intel Corporation. Use, duplication or disclosure is subject to restrictions stated in Intel's software license, or as define in ASPR-7-104.9(a)(9).

The following are trademarks of Intel Corporation and its affiliates and may be used only to identify Intel products:

Above	iDIS	iPSC	OTP
BITBUS	iLBX	iRMX	PC BUBBLE
COMMputer	Im	iSBC	Plug-A-Bubble
Concurrent File System	iMDDX	iSBX	PROMPT
Concurrent Workbench	iMMX	iSDM	Promware
CREDIT	Insite	iSXM	QueX
Data Pipeline	int _e 1	KEPROM	QUEST Programming
Direct-Connect Module	int _e IBOS	Library Manager	Quick-Pulse
FASTPATH	Intelevision	MAP-NET	Ripplemode
GENIUS	int _e ligent Identifier	MCS	RMX/80
ICE	int _e ligent Programming	Megachassis	RUPI
i	Intellec	MICROMAINFRAME	Seamless
im	Intellink	MULTIBUS	SLD
ICE	iOSP	MULTICHANNEL	SugarCube
iCEL	iPDS	MULTIMODULE	UPI
iCS		ONCE	VLSiCEL
iDBP		OpenNET	4-SITE

UNIX is a trademark of AT&T
 Excelan is a trademark of Excelan Corporation
 EXOS is a trademark or equipment designator of Excelan Corporation
 Green Hills Software, C-386, and FORTRAN-386 are trademarks of Green Hills Software, Inc.
 Lucid and Lucid Common Lisp are trademarks of Lucid, Inc.
 XENIX is a trademark of Microsoft Corporation
 VAST2 is a registered trademark of Pacific-Sierra Research Corporation
 VP/ix is a trademark of INTERACTIVE Systems Corporation and Phoenix Technologies, Ltd.
 NFS is a trademark of Sun Microsystems
 Sun Microsystems and the combination of Sun and a numeric suffix are trademarks of Sun Microsystems
 VADS and Veridx are registered trademarks of Verdex Corporation
 APSO is a service mark of Verdex Corporation
 GVAS is a trademark of Verdex Corporation
 Ethernet is a registered trademark of XEROX Corporation
 VMS is a trademark of Digital Equipment Corporation

REV.	REVISION HISTORY	DATE
-001	Original Issue	12/87
-002	Revision	09/89

CAUTION

This equipment has been tested and found compliant with the limits for a Class A digital device, pursuant to Part 15 of the FCC rules. These limits are designed to provide reasonable protection against harmful interference when the equipment is operated in a commercial environment. This equipment generates, uses, and can radiate radio frequency energy and, if not installed and used in accordance with the instruction manual, may cause harmful interference to radio communications. Operation of this equipment in a residential area is likely to cause harmful interference in which case the user will be required to correct the interference at his own expense.

This equipment is a Class A digital apparatus which complies with the Canadian Radio Interference Regulations CRC c.1374.

The cabinets have the following safety certifications:

UL 478 listed — Information Processing and Business Equipment
CSA C22.2, No. 220 — Information Processing and Business
Equipment
TUV — IEC 950
EN60 950 — European Norm Standard

In addition to the EMI certifications listed above, it is also certified VDE 9871, Class A.

RESTRICTED RIGHTS

Use, duplication or disclosure by the U.S. Government is subject to restrictions as set forth in subparagraph (c) (1) (ii) of the rights in Technical Data and Computer Software clause at 52.227-7013. Intel Corporation, 3065 Bowers Avenue, Santa Clara, California 95051.

PREFACE

PURPOSE/SCOPE

This manual provides detailed instructions for installing the iPSC/2 system. It includes information on installing both the standard cabinet and the optional compact cabinet. It also serves as a reference for your site system administrator.

The manual assumes that you have been through the customer engineer training class, and so are familiar with the iPSC/2 hardware and software in general.

ORGANIZATION

The organization is described in Chapter 1.

APPLICABLE DOCUMENTS

For more information, refer to the following members of the iPSC/2 manual set:

iPSC®/2 Site Preparation Guide

This manual describes how to prepare the site for an iPSC/2 system installation.

iPSC®/2 System Administrator's Guide

This manual provides a detailed description of the system administration tasks related to operating and maintaining an iPSC/2 system.

TABLE OF CONTENTS

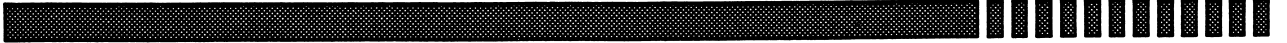

CHAPTER 1 INTRODUCTION

INTRODUCTION.....	1-1
INSTALLATION STRATEGY	1-2
TOOLS.....	1-2

CHAPTER 2 UNPACKING THE SYSTEM

INTRODUCTION.....	2-1
CHECKING THE SHIPPING CONTAINERS	2-1
INSPECTING THE SHIPPING CONTAINERS	2-2
PRIOR TO UNPACKING	2-2
UNPACKING THE CABINET(S)	2-3
Inspection Instructions	2-4
Physical Setup	2-4
UNPACKING THE MONITOR.....	2-5



Inspection Instructions..... 2-5

Physical Setup..... 2-5

UNPACKING THE SRM SYSTEM UNIT..... 2-6

Inspection Instructions..... 2-6

Physical Setup..... 2-6

UNPACKING THE ACCESSORIES CONTAINER..... 2-7

Inventory Instructions 2-7

Physical Setup..... 2-7

UNPACKING THE SOFTWARE CONTAINER 2-8

UNPACKING THE MANUALS CONTAINER 2-8

CHAPTER 3 INSTALLING THE SRM

INTRODUCTION..... 3-1

Installing the Monitor 3-1

Installing the SRM System Unit..... 3-2

INSTALLATIONS OUTSIDE OF THE UNITED STATES 3-4

CHAPTER 4 INSTALLING STANDARD CABINETS

INTRODUCTION..... 4-1

INSTALLING THE CABINETS 4-1

Opening Front and Rear Cabinet Doors..... 4-2

OPENING THE FRONT DOOR4-2
OPENING THE REAR DOOR.....4-2
Joining Multiple Cabinets4-2
REMOVING FRONT AND REAR DOORS4-2
 Disconnecting the LED Cable from the Standard Cabinet.....4-3
 Removing the Doors.....4-3
CONNECTING CABINETS AT THEIR BASES.....4-4
CONNECTING UNITS AT THEIR TOPS4-6
Checking the Power Plugs.....4-7
Installing the RS-422 Diagnostic Link Cable in Multiple Cabinets4-7
Installing Computational Communication Cables4-10
Installing I/O Connections4-10
Installing the Cable from the System Resource Manager to Unit 04-12
Attaching Front Base Filler Plates (Multiple Units Only)4-14
Attaching Rear Base Filler Plates (Multiple Units Only).....4-14
Attaching Side Grills.....4-16
Replacing the Doors4-16
Connecting the Power Cables4-16
Attaching the Legs to the Standard Cabinet4-17
CLOSING THE CABINET DOORS.....4-18
LEVELING THE CABINETS4-18

CHAPTER 5 INSTALLING OPTIONAL COMPACT CABINETS

INTRODUCTION.....	5-1
INSTALLING THE CABINETS.....	5-1
Opening Front and Rear Cabinet Doors	5-2
OPENING THE FRONT DOOR	5-2
OPENING THE REAR DOOR.....	5-2
Joining Multiple Cabinets	5-2
REMOVING FRONT AND REAR DOORS	5-3
CONNECTING THE CABINETS AT THEIR BASES	5-5
CONNECTING THE CABINETS AT THEIR TOPS.....	5-5
Installing the RS-422 Diagnostic Link Cable in Multiple Cabinets	5-7
OPTIONAL COMPACT CABINET TO OPTIONAL COMPACT CABINET.....	5-7
OPTIONAL COMPACT CABINET TO STANDARD I/O CABINET	5-9
Installing Computational Communication Cables	5-9
CHANNEL 5 CONNECTIONS (TWO- AND FOUR-UNIT SYSTEMS).....	5-9
CHANNEL 6 CONNECTIONS (FOUR-UNIT SYSTEMS ONLY)	5-10
Connecting the Jumper Wire on Unit 0	5-12
Installing the AC Enable Cable in Multiple Cabinets.....	5-13
Installing I/O Connections	5-14
Installing the Cable from the System Resource Manager to Unit 0	5-15
Attaching Front Base Filler Plates (Multiple Units Only)	5-15
Attaching Rear Base Filler Plates (Multiple Units Only).....	5-16
Attaching Side Grills.....	5-18
Replacing the Doors	5-18

Connecting the Power Cables5-18

Attaching the Legs5-19

CLOSING THE CABINET DOORS5-20

LEVELING THE CABINETS5-20

CHAPTER 6 INSTALLING THE OPTIONAL STAND-ALONE TAPE DRIVE

INTRODUCTION.....6-1

INSTALLING THE TAPE DRIVE.....6-1

 Routing and Connecting the Cable6-2

CHAPTER 7 POWER UP and CHECKOUT

INTRODUCTION.....7-1

APPLYING POWER.....7-1

 Applying Power to the SRM Monitor7-2

 Applying Power to the SRM System Unit.....7-2

 Applying Power to Standard Cabinets7-3

 Applying Power to Optional Compact Cabinets7-3

CUBE DIAGNOSTIC PROGRAM7-5

APPENDIX A COMM BOARD UPGRADES

INTRODUCTION..... A-1

LIST OF ILLUSTRATIONS

Figure 1-1. Installation Strategy 1-3

Figure 3-1. Rear Panel of SRM System Unit3-2

Figure 3-2. Standard Plugs for Domestic and International Installations3-4

Figure 4-1. L-Shaped Door Bracket 4-4

Figure 4-2. Wedge Adapter Castings and Covers 4-5

Figure 4-3. Splice Plate 4-6

Figure 4-4. Backplane in Standard Cabinets 4-8

Figure 4-5. Diagnostic Cable Routing between Standard Cabinets..... 4-9

Figure 4-6. Channel 6 Cable Connections for D7 System in Standard Cabinet4-11

Figure 4-7. The Standard Cabinet I/O Panel and SRM Cable Routing.....4-13

Figure 4-8. Base Filler Plates 4-15

Figure 4-9. Standard Cabinet Leg 4-17

Figure 5-1. Rear Door Handle 5-3

Figure 5-2. L-Shaped Door Bracket 5-4

Figure 5-3. Wedge Adapter Castings and Covers 5-6

Figure 5-4. Splice Plate.....5-7

Figure 5-5. Internal Diagnostic Link Cabling5-8

Figure 5-6. Channel 5 Cable Routing.....5-10

Figure 5-7. Channel 5 64-Pin Cable Connections.....5-11

Figure 5-8. Coaxial Cable Routing5-12

Figure 5-9. Channel 6 64-Pin System Cable Connection5-13

Figure 5-10. AC Enable Cable Connection for Optional Compact Cabinets.....5-14

Figure 5-11. Cabinet to System Resource Manager Cable Connections5-16

Figure 5-12. Base Filler Plates.....5-17

Figure 5-13. Compact Cabinet Leg5-19

Figure 6-1. I/O Panel for Stand-Alone Tape Drive Connection6-2

INTRODUCTION

This manual provides detailed instructions on how to install a new iPSC@/2 system. It is intended to be used by iSC Customer Engineers or other people who have been qualified by the iSC Customer Engineer training class. The contents of the manual are as follows:

Chapter 1, "Introduction", describes the overall installation strategy and lists the tools you will need to complete the installation.

Chapter 2, "Unpacking the System", describes how to unpack, inventory, and position it prior to installation.

Chapter 3, "Installing the SRM", describes how to install the System Resource Manager (SRM).

Chapter 4, "Installing Standard Cabinets", describes how to install standard cabinets containing either computational nodes or I/O nodes and peripherals.

Chapter 5, "Installing Optional Compact Cabinets", describes how to install systems consisting of optional compact cabinets containing computational nodes, and how to install a Concurrent I/O system (which must be in a standard cabinet) in such a system.

Chapter 6, "Installing the Optional Stand-Alone Tape Drive", describes how to install this option in an iPSC/2 system.

Chapter 7, "Power Up and Checkout", describes how to apply power to the system and execute the CDP diagnostic tests.

Chapter 8, "Installing Network Hardware", describes how to connect the SRM to the local area network.

Appendix A, "Comm Board Upgrades", is intended to be used for upgrades where you need to add I/O to a previously installed system. It describes how to replace the communications (comm) board in systems consisting of compact cabinets with old comm boards in them.

INSTALLATION STRATEGY

The overall installation strategy for installing the iPSC/2 hardware is as follows:

- Install the system resource manager, power up, and verify operation. UNIX is automatically booted at power up.
- Install the cube and connect it to the system resource manager.
- Power up system...confidence tests are automatically executed.
- Run the Cube Diagnostic Program (CDP) to verify proper operation of the entire system.
- If customer is connecting the computer to a network, configure the local area network (LAN) connection.

Figure 1-1 is a block diagram that illustrates the installation process.

TOOLS

You need the following tools for unpacking and installing the iPSC/2 system:

Unpacking	9/16" open-ended wrench tape cutter
Installing	3/16" Allen wrench 5/32" Allen wrench 5/16" open, box, or ratchet wrench 5/16" thin-wall nut driver small straight-slot screwdriver #1 small-tip Phillips screwdriver #2 medium-tip Phillips screwdriver

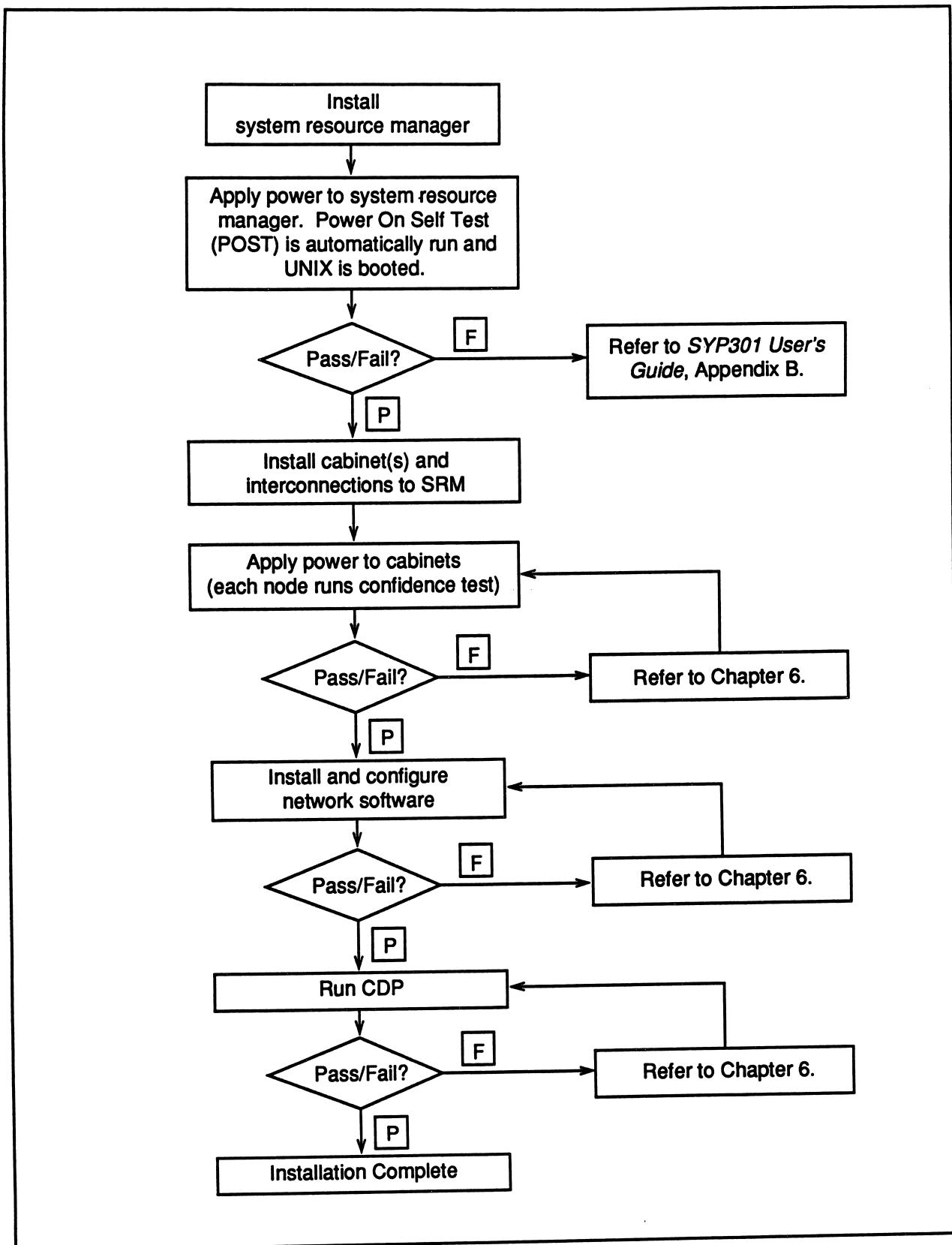

Figure 1-1. Installation Strategy

UNPACKING THE SYSTEM **2**

INTRODUCTION

This chapter explains how to unpack the iPSC/2 system components. Perform the procedures in the order presented. This chapter describes the following:

- Checking shipping containers to verify that all of them have arrived.
- Inspecting shipping containers for visible and concealed damage and what to do if you discover any damage.
- Unpacking, inventory, inspection, and physical setup instructions for each component.

NOTE

Advise the customer to keep all shipping materials for at least the first month in case anything must be returned. Suggest that the customer keep the materials permanently if a move is planned, because moving the system in the shipping containers helps reduce the risk of damage.

CHECKING THE SHIPPING CONTAINERS

Before you do any unpacking, make sure that all of the system shipping containers have arrived at the customer's site. The contents of the shipping containers should be as follows:

- Computational and/or I/O system cabinet(s)
- Intel's 301 computer, user manuals, and power cords, the keyboard carton, and the SRM cables

- Monitor, user guide for the monitor, and power cord
- iPSC/2 accessories: cables, kits, and other miscellaneous items
- Binder containing system software and TCP/IP manual
- Complete set of iPSC/2 manuals and the UNIX System V manual set

INSPECTING THE SHIPPING CONTAINERS

Before opening the shipping containers, inspect them to see if there are any signs of damage:

Visible damage If the freight bill was signed by someone when the equipment was delivered, but shipping container damage was not noted at the time, you should write down the extent and type of damage. This can later be used if a claim must be filed.

Concealed damage If after unpacking the system (described later in this section), you find equipment damage, call the carrier and request an inspection. Save the shipping container and all the packing material. Make sure that the customer retains a copy of the inspection report.

Follow these guidelines if there are problems:

Damage If the equipment is visibly damaged, the claim must be filed with the carrier who delivered the equipment.

Malfunction If the equipment does not work but is not visibly damaged call iSC Customer Support for assistance at one of the following:

1-503-629-7777 (Customer Support Hotline in Oregon)

1-800-421-CUBE (Customer Support Hotline outside of Oregon)

(44)793 696 619 (in England)

Your local Intel Sales Office (in Europe)

support@isc.intel.com(csnet address)

...!omepd!intelisc!support (uucp address)

PRIOR TO UNPACKING

Before you unpack the system, do the following:

1. Review the layout plan with the customer and verify AC voltage, air flow, adequate room, etc. as described in the *iPSC®/2 Site Preparation Guide*.
2. If necessary, move the shipping containers to an open area with adequate room to unpack the equipment. Unless it is unavoidable, do not move the shipping containers into the installation site. Move the equipment there after it is unpacked.

UNPACKING THE CABINET(S)

The following instructions explain how to unpack and position the systems cabinets. These instructions apply both to standard cabinets and optional compact cabinets.

If there is more than one cabinet, this unpacking procedure applies to all.

1. Position the crate so that you have access to the four bolts that hold on the front door of the crate.
2. Use a 5/16" open-end, box, or ratchet wrench to unscrew and remove the four bolts.
3. Remove the door of the crate. Notice that there is a base retainer board attached to the bottom of the inside of the door.
4. Turn the door over and lay it on the floor to form a ramp with the base retainer board directly in front of the crate and the front of the door facing up. Line up the Velcro strips on the ramp with the Velcro strips on the pallet.
5. Unscrew the bolts connecting the crate to the base pallet. Use the same 9/16" wrench.
6. Tip the crate off the pallet, away from the cabinet, and lay it on the floor.
7. Attach the two Velcro strips on the ramp to the Velcro strips on the base pallet.

WARNING

The units are quite heavy. The standard cabinet weighs 475 pounds, and the optional compact cabinet weighs 215 pounds. Do not attempt to move the cabinet by yourself; make sure that there are at least two people, one on either side of the crate.

8. Grasp the cabinet and roll it carefully down the ramp to the floor.
9. Remove the styrofoam covering the top of the cabinet.
10. After you have placed the units in the installation location, remove the plastic wrap around the power cord.
11. Each crate contains a single cabinet. To verify each unit's identity, do the following:
 - A. Open the front door of each cabinet by pulling out the lever that is located at the bottom right.
 - B. On the front door panel is a label that indicates the cabinet's number. Cabinets are numbered consecutively from 0.

Inspection Instructions

Inspect all of the parts for evidence of damage. Check for scratches and dents.

For any damage you find:

- If the damage appears to have happened during shipment, contact the carrier.
- If the damage appears to have happened during manufacture, contact iSC Customer Support.

Physical Setup

1. Move the cabinets into the general area in which they will be located (according to the customer's layout plan) once they are installed.
2. Arrange the units in order from right to left (looking at the units from the front).

NOTE

If there is more than one cabinet, you must place them in numerical order: 0, 1, etc. 0 is on the right.

The installation site, with the required power, should already be prepared for the system according to the *iPSC®/2 Site Preparation Guide*. Some of the physical requirements for the site are as follows:

- Cabinet 0 must not be more than 10 meters (38.2 feet) from the System Resource Manager (SRM).
- The cabinets must be placed in a dry, level location.
- There must be enough space behind and in front of the cabinets for air flow and access to cables.

Refer to the *iPSC®/2 Site Preparation Guide* for more details.

UNPACKING THE MONITOR

Open the carton using a tape cutter. This carton should contain the following items:

Quantity	Item
1	Display unit with video cable
1	The monitor's user's guide
1	AC power cord (this may be permanently attached to the monitor. If the AC power cord is separate, see the SRM system unit container for an alternate jumper power cord to connect the monitor to the SRM system unit.)

Inspection Instructions

Inspect all of the parts for evidence of damage. Check for scratches and dents.

For any damage you find:

- If the damage appears to have happened during shipment, contact the carrier .
- If the damage appears to have happened during manufacture, contact iSC Customer Support.

Physical Setup

Move the monitor to the installation site and locate it according to the customer's layout plan and the following requirements:

- It must not be more than 61 cm (2 feet) from the SRM system unit.
- It must be placed directly on a table or desk top.
- There must be additional space behind the monitor (at least 15.34 cm or 6 inches) for access to cables.

UNPACKING THE SRM SYSTEM UNIT

Open the carton using a tape cutter. This carton should contain the following:

Quantity	Item
1	System unit
1	AC power cord
1	SYP301 Installation and User's Guide
1	Bell Technologies Tape Driver User's Manual
1	Keyboard
	Miscellaneous manuals and software

Inspection Instructions

Inspect all of the parts for evidence of damage. Check for scratches, dents, and damaged cables.

For any damage you find:

- If the damage appears to have happened during shipment, contact the carrier .
- If the damage appears to have happened during manufacture, contact iSC Customer Support.

Physical Setup

1. Move the system unit into the installation site and locate it according to the customer's layout plan and the following requirements:
 - It must be no more than 10 meters (38.2 feet) from Cabinet 0.
 - It must be placed directly on a table or desk top.
 - There must be enough space around it for air flow and access to cables.
2. Remove the keyboard from its carton and place it near the SRM system unit.

Refer to the *iPSC®/2 Site Preparation Guide* for more details.

UNPACKING THE ACCESSORIES CONTAINER

Before unpacking the accessories container, move it to the installation site. Do not remove any of the contents in an area outside of the installation area. Open the container using a tape cutter.

Inventory Instructions

Within this container are two cartons. The kits that arrive with systems consisting of more than one cabinet should contain the appropriate number of items to connect the cabinets. If the system consists of optional compact cabinets for computational nodes and standard cabinets for I/O, leg finish hardware will be duplicated because different style cabinets cannot be joined. In general, cartons contain the following items:

- Carton 1**
- Leg assembly kit: four leg castings, four covers, four levelers, and associated hardware.
 - Wedge adapter kit (multiple cabinets only): wedge castings, adapter covers, levelers, and associated hardware.
 - Filler plate kit (multiple cabinets only): front filler plate(s), rear filler plate(s).
 - Splice plate kit (multiple cabinets only): splice plates and hardware
 - Side grill kit: side grills and hardware.
- Carton 2**
- Package of grounding nuts and washers.
 - 64-pin radial cables (for multiple computational units only).
 - SRM direct-connect interface cable.
 - RS-422 10-pin ribbon cable (multiple-cabinet systems only)
 - AC enable cable (multiple optional compact cabinet systems only).

Physical Setup

With the accessories carton at the installation site, do the following:

1. Place all assembly kits near the cabinet(s).
2. Place the monitor's power cord near the SRM system unit.
3. Place the grounding hardware and cables near the rear of the cabinets.
4. Remove the keyboard and place it near the SRM system unit.

UNPACKING THE SOFTWARE CONTAINER

The software container holds the following:

Quantity	Item
1	iPSC/2 Customer Letter
1	iPSC/2 Release Notes
1	UNIX boot diskette
1	UNIX Remote Terminals diskette
1	UNIX System V software cartridge tape
1	iPSC/2 System software cartridge tape
3	TCP/IP installation diskettes
1	Ethernet driver diskette
1	TCP/IP manual set

Remove the software diskettes, cartridge tape, and TCP/IP manuals. Have the customer place these on a bookshelf.

UNPACKING THE MANUALS CONTAINER

The manuals container holds the following:

- UNIX System V manuals
- iPSC/2 manuals, with binders, tab dividers, and labels

Remove the binders and manuals and have the customer place them on a bookshelf.

INTRODUCTION

This chapter provides detailed instructions for installing the System Resource Manager (SRM). Installing the SRM is a simple two-step procedure in which you first install the monitor, and then the system unit.

Installing the Monitor

To install the monitor, you must connect its power cord to a power source and its video cable to the SRM system unit. The procedure is as follows:

1. Connect the video cable coming from the monitor to the 9-pin signal connector in Slot 4 on the back of the SRM, as shown in Figure 3-1.
2. The monitor can be one of two types: one has a nondetachable power cord, and the other has a detachable power cord.
 - If the monitor has a nondetachable power cord, you must plug it into the wall power receptacle.

NOTE

If you are installing the system outside of the United States, check the plug on the power cord to make sure it conforms to local electrical standards. Refer to the section entitled "Installations Outside of the United States" for instructions.

- If the monitor has a detachable power cord, you should also have another cord, the AC jumper cord. Do not use the detachable power cord intended to be plugged into the wall socket. Instead, use the AC jumper power cord provided with the SRM to connect the monitor directly to the system unit. Plug one end of the AC jumper power cord into the power connector on the back of the monitor. Plug the other end into the receptacle labeled MONITOR on the back of the SRM system unit. Refer to Figure 3-1.

The monitor voltage is set at the factory and is not field configurable. If you need to change it for any reason, call iSC Customer Support.

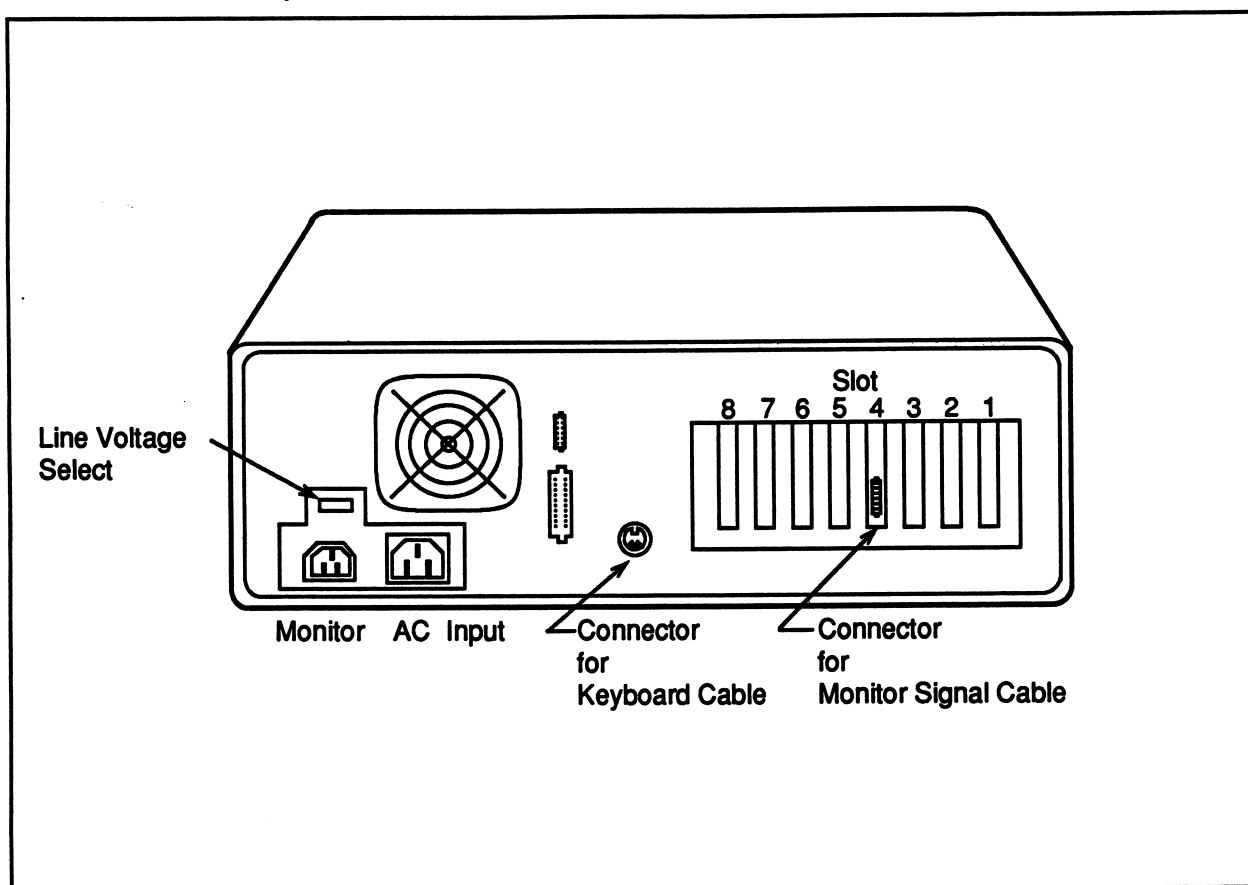

Figure 3-1. Rear Panel of SRM System Unit

Installing the SRM System Unit

Refer to Figure 3-1 and follow these instructions to install the SRM and keyboard:

1. Check the switch labeled "LINE VOLTAGE SELECT" on the back of the system unit before you connect the power cord. For the United States and Canada, the proper setting is 115V; for Europe, the proper setting is 230V.

NOTE

If you are installing the system outside of the United States, check the plug on the power cord to make sure it conforms to local electrical standards. Refer to the section entitled "Installations Outside of the United States" for instructions.

2. Install the keyboard by inserting its cable connector into the round socket labeled "KEYBOARD" on the back of the system unit. The groove in the connector should be pointing up when you insert it.
3. Plug the system unit's power cord into the wall power receptacle.
4. Press the monitor's ON/OFF switch so it is in the ON position. The screen will not be illuminated until the SRM system unit is turned on.
5. Turn on the system unit by pushing the ON/OFF switch to the ON position. After you power up the system unit, a Power On Self Test (POST) is executed automatically and UNIX is booted. Refer to Chapter 4 for more information on power up and checkout.
6. After you are satisfied that the system unit is operating properly, follow the following sequence of steps to power the system down:

- A. Log on as root.
- B. Invoke the shutdown command by entering the command:

```
shutdown -g0 -y
```

This shuts UNIX down gracefully.

- C. Wait for the following message to appear on the screen:

```
Reset the CPU to reboot
```

- E. When the message appears, turn the system unit off by pushing the ON/OFF switch to the OFF position. If the monitor is plugged directly into the wall, turn the monitor off as well. If the monitor gets its power from the system unit, it is off when the system unit is turned off. Refer to Chapter 6 for more information on power down.

INSTALLATIONS OUTSIDE OF THE UNITED STATES

There are two standard types of power plugs installed on the cabinets at the factory: one for installations in the United States, Canada, and Japan, and the other for installations in other countries. Figure 3-2 shows these plugs.

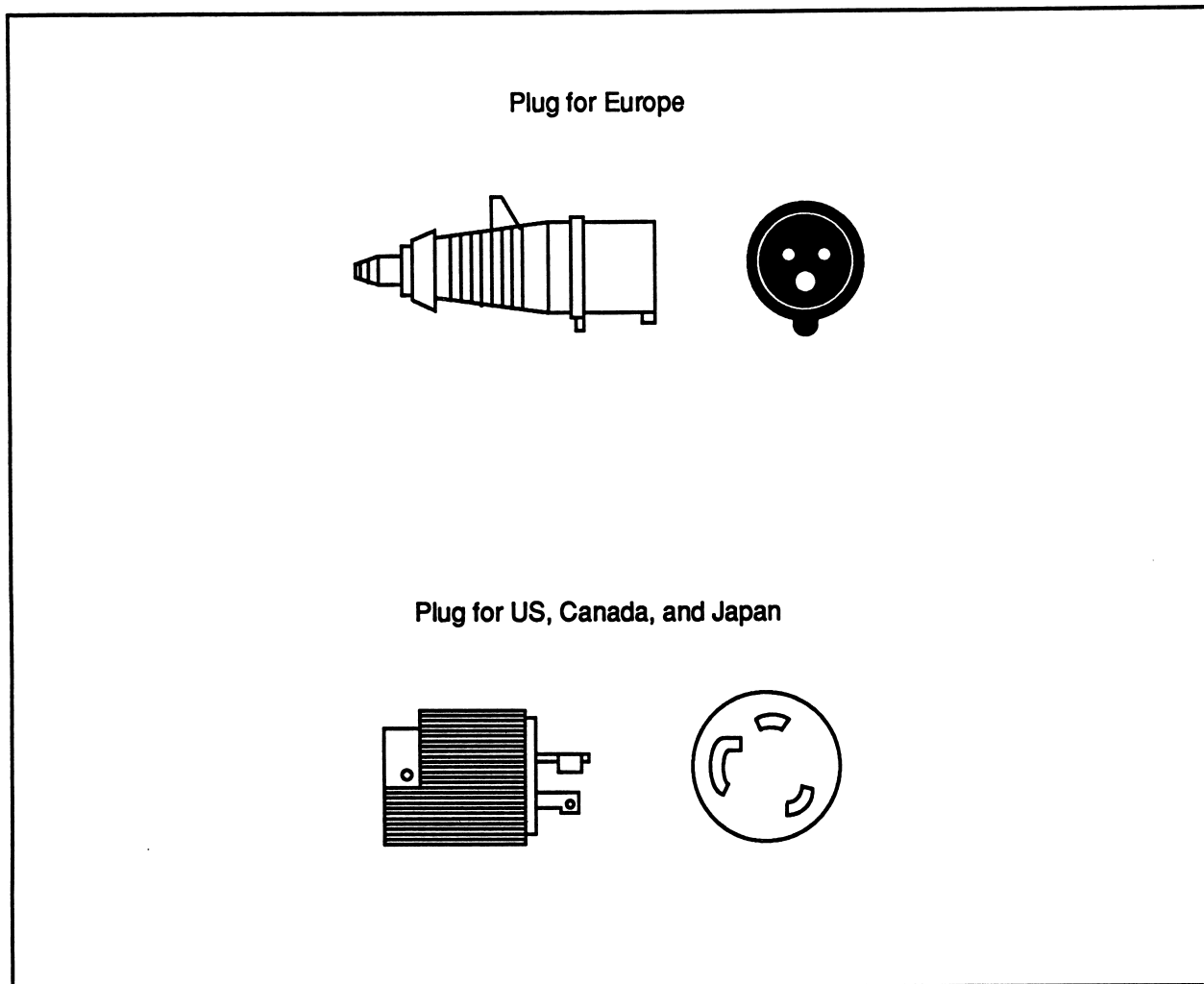

Figure 3-2. Standard Plugs for Domestic and International Installations

You may have to replace the power plug on the monitor, system unit, or cabinet(s) to conform to local electrical standards. If you replace the plug on the power cord or change the cord itself, note the following warning and wire color coding:

WARNING

To prevent possible electrical shock or damage to the system, only qualified technical personnel should change the power cord plug. Also, check local electrical standards before selecting a power cord plug.

When changing the power cord plug make sure you connect all the wires properly. For installations outside the United States, the power cord has the following colored wire convention:

- The wire that connects to earth ground is either green with yellow stripes or solid green.
- The wire that connects to the neutral or grounded side of the power line is either light blue or white.
- The wire that connects to the hot or ungrounded side of the power line is either brown or black.

INSTALLING STANDARD CABINETS

4

INTRODUCTION

This chapter provides detailed instructions for installing cabinets containing computational nodes or I/O nodes and peripheral devices. The instructions in this chapter are for new installations in which all cabinets are standard cabinets. Installations of optional compact cabinets are described in Chapter 5. Be sure you have finished unpacking and positioning the components (as described in Chapter 2) and have installed the SRM (as described in Chapter 3) before you proceed with the installation.

The recommended order for installing the hardware is as follows:

1. Install the cabinets with compute nodes
2. Install the I/O cabinets
3. Connect the SRM to Unit 0
4. Install the finish hardware and the legs

INSTALLING THE CABINETS

The cabinet(s) should already be in their final location. Make sure there is adequate room for you to move around them. This section describes how to install one or more standard cabinets. The general steps are as follows:

1. Open cabinet front and back doors.
2. Join multiple cabinets.
3. Install cables that run between attached cabinets. These are referred to as internal cables in this manual. Cables that are completely contained in any single cabinet should be installed at the factory. Their installation is not covered in this manual.
4. Install external cables on I/O units.
5. Connect the SRM to Cabinet 0.
6. Attach the base filler plate (multiple cabinets only).
7. Attach the legs.

Opening Front and Rear Cabinet Doors

You need to open the front and rear doors of all cabinets, whether you are installing one or multiple units.

OPENING THE FRONT DOOR

Find the lever at the bottom right of the front door. Open the front door by moving the lever counterclockwise 180 degrees.

OPENING THE REAR DOOR

To open the rear door of the standard cabinet, insert a 3/16" allen wrench in the allen screw on the right-hand top of the rear door. Turn it counterclockwise approximately 90 degrees to release the latch. You can then pull the door open.

NOTE

Only qualified customer engineers should open the rear door.

Joining Multiple Cabinets

Multiple cabinets of the same size must be joined. To do this, follow these steps (as detailed in the following sections):

1. In multiple cabinet installations, remove specified cabinet doors :
2. Connect the cabinets at the bases.

REMOVING FRONT AND REAR DOORS

When you are installing multiple cabinets of the same kind, you must remove some of the door to connect the cabinets at their bases. These guidelines describe which doors you need to remove:

- Remove the front door of the right-most cabinet.
- Remove the rear door of the left-most cabinet.
- Remove both front and rear doors of any cabinets between them.

To remove the front door of the cabinets, you need to disconnect the cable that runs from the LED board to the door. When you have unhooked this, the front and rear doors of the cabinets are connected to the body of the cabinets in the same way.

Disconnecting the LED Cable from the Standard Cabinet

Before you remove the front door, you must first disconnect the cable that runs from the LED board in the door to the LED adapter board in the cabinet. To disconnect it from the LED adapter board, proceed as follows:

1. Go to the back of the cabinet and find the small LED adapter board that is on the right-hand side of the inside of the iPSC/2 nameplate at the front of the unit. The door cable consists of a signal cable, plugged into connector J7 (the top right-hand connector), and a power cable, plugged into connector J6 (the bottom right-hand connector). Disconnect both of these to free the cable.
2. Go around to the front of the cabinet and remove the four small screws holding the name plate at the top to the cabinet frame.
3. Pull the name plate very slightly away from the frame and slide it to the right to create a large enough space to pull the end of the door cable through.
4. Pull the door cable through the opening so it is free of the main cabinet. You can now remove the front door.

Removing the Doors

To remove doors, follow this procedure:

1. Locate the L-shaped brackets that hold the hinges at the top and bottom of the door, as shown in Figure 4-1.
2. Use a #2 medium-tip Phillips screwdriver to remove the three screws from the L-shaped bracket at the bottom of the door.
3. Remove the three screws from the L-shaped bracket at the top of the door in the order shown in Figure 4-1.
4. Lift the door outward to release it from its hinges.
5. Set the doors and screws aside. You do not replace them until the end of the installation.

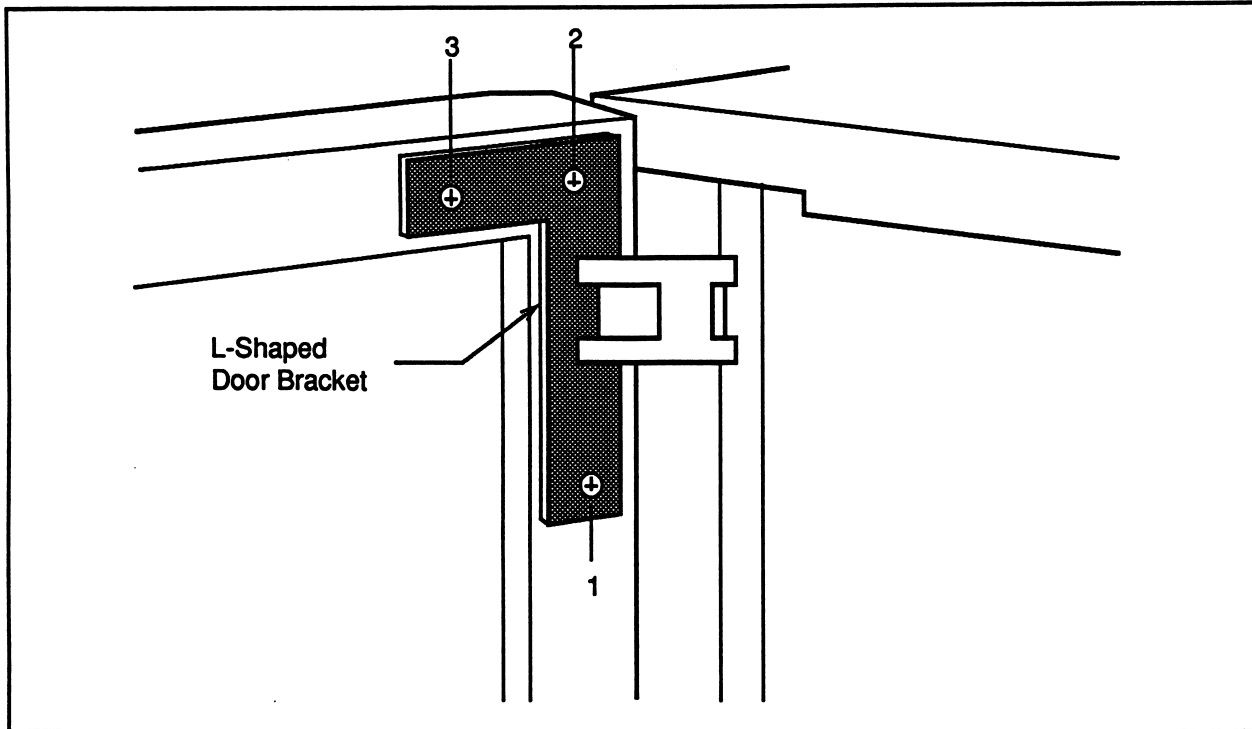

Figure 4-1. L-Shaped Door Bracket

CONNECTING CABINETS AT THEIR BASES

The first place you connect adjoining cabinets is the triangular space formed when the bases of two cabinets are touching, as shown in Figure 4-2. Do this on both sides of the cabinets.

Make sure you have the following items (from the accessories carton):

- Two wedge adapter castings
- Four 1/4-20 UNC by 1/2" long button head cap screws
- Two wedge adapter covers with Velcro seals

Wait until the end of the installation to adjust the levelers and install the foot covers.

1. Roll the cabinets together so they are flush against one another. The units must be in order from right to left, Unit 0 on the right, then Unit 1 on its left, etc.
2. Make sure the leveler is screwed all the way into the adapter casting.
3. Slide the tabs on the back of the wedge adapter casting up under the bases of the units, matching the two screw holes (one on each corner of the unit) as shown in Figure 4-2.

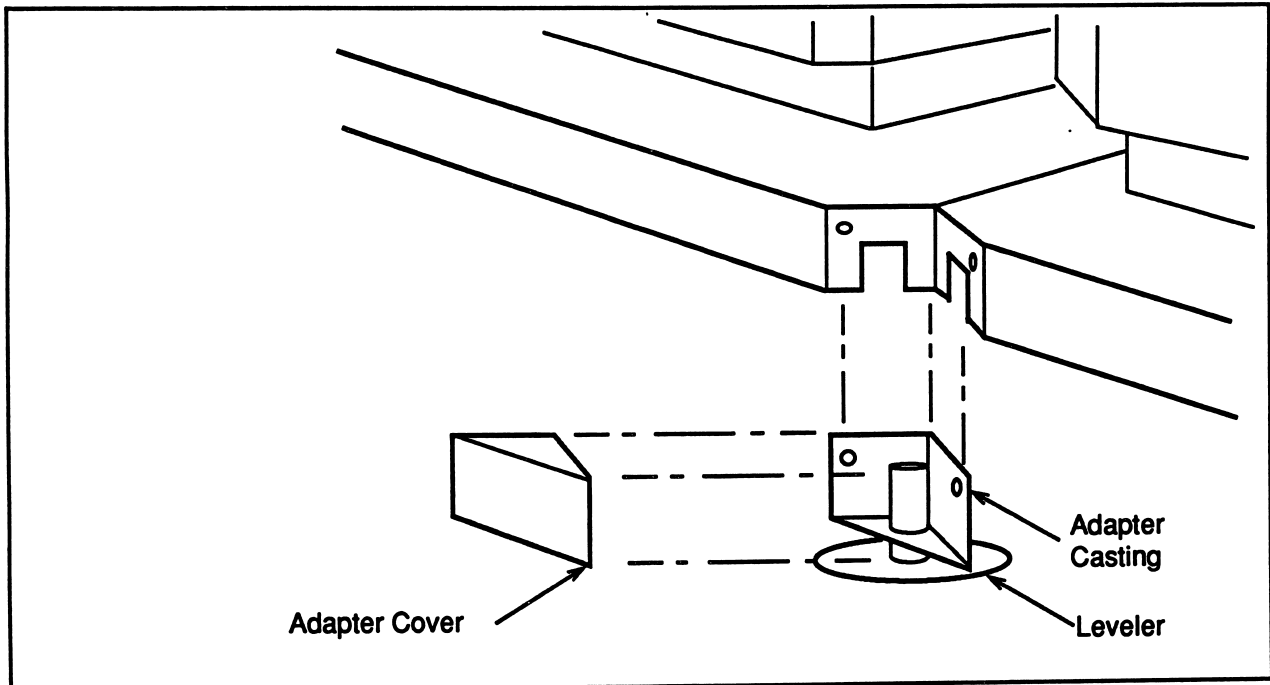

Figure 4-2. Wedge Adapter Castings and Covers

CAUTION

You may need to tilt the system slightly to insert the tabs. Do not attempt to do this by yourself, because the cabinets are quite heavy.

4. Insert a button head cap screw into each hole.

NOTE

Before you tighten the screws on the wedge adapter castings, position both the front and back castings and place the screws in the holes.

5. Start all of the screws with a 5/32" Allen wrench, then tighten them in place.

CONNECTING UNITS AT THEIR TOPS

Follow this procedure once for each two adjoining units. For each two units being connected, you should have the following ready:

- Two splice plates
- Eight #4-40 UNC by 1/4" long Phillips-head flat head screw

Install the splice plates as follows:

1. Locate the two holes punched in the door seal (approximately four inches from top).
2. Gently peel up the seal and the mesh over the holes from the edge of the cabinets to be joined.

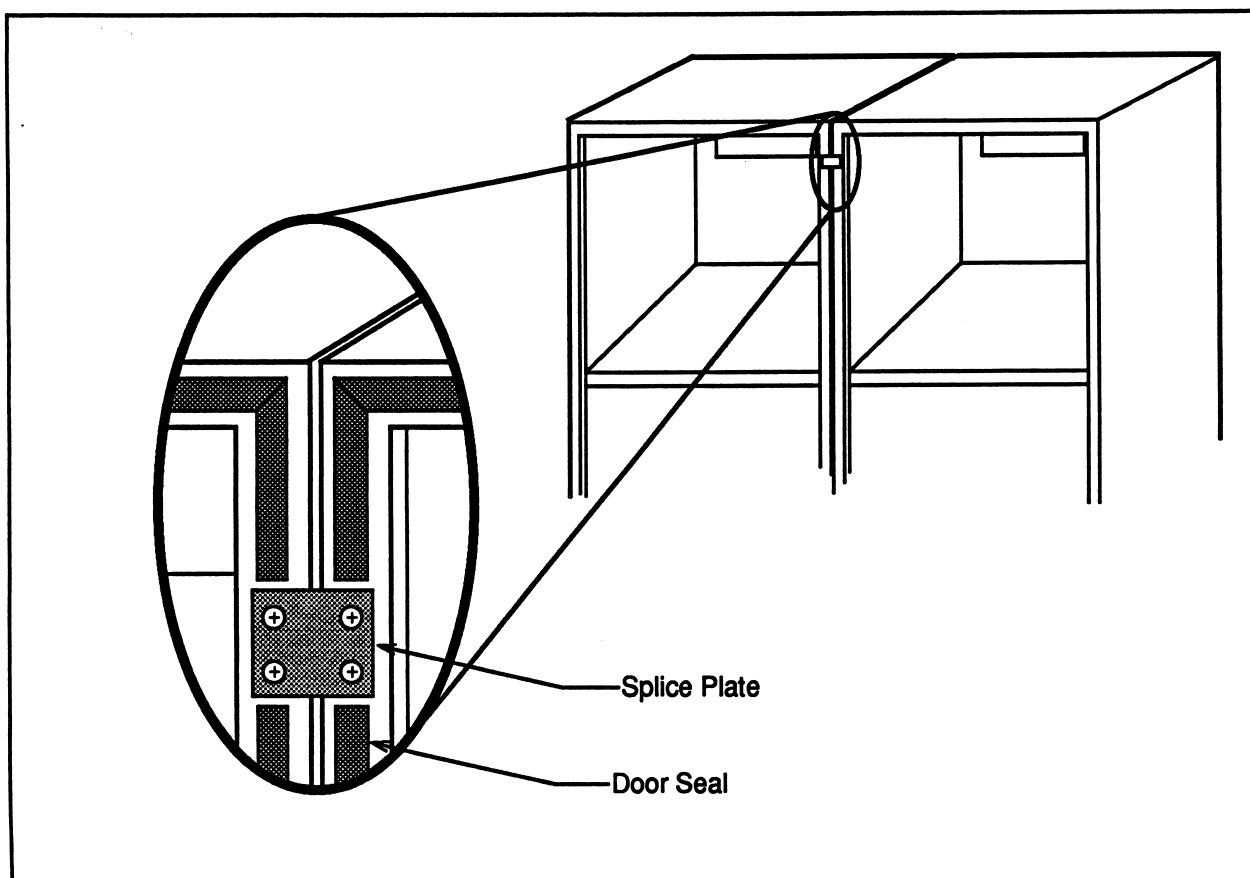

Figure 4-3. Splice Plate

CAUTION

Do not damage or cut the seal.

3. Slide the splice plate under the door seal.
4. Align the splice plate over the four holes (two on each cabinet) as shown in Figure 4-3.
5. Insert a flat head screw into each screw hole and start each of the screws.
6. After all screws have been started, tighten both the splice plate and lower wedge screws using a #1 small-tip Phillips screwdriver. Be careful not to strip the threads.
7. Press the seal back down over the splice plate.

Checking the Power Plugs

Check all of the power plugs on the power strip to ensure that no connections were loosened during shipment.

Installing the RS-422 Diagnostic Link Cable in Multiple Cabinets

In multiple cabinet systems, the system accessories include one or more 10-pin ribbon cables. This cable is an RS-422 connection for the USM diagnostic channel. The following section describes how to connect this cable.

1. Find the backplane for the top card cage in Unit 0. The backplane is illustrated in Figure 4-4. If the backplane for this set of nodes is behind the bracket holding the power supply, take out the two screws holding the right side of the cage to the cabinet frame. Swing the cage out on its hinges to expose the backplane. It is not necessary to disconnect any of the power cables. Refer to Figure 4-4.
2. Route the diagnostic link cable through the cutouts in the sides of the base castings as illustrated in Figure 4-5.
3. Plug the 10-pin female connector at the end of the RS-422 cable into the male connector (J16) on the left side of the backplane of Unit 0. Find the arrow on the female connector. Insert the connector so that the arrow points to pin 1 (bottom, right).
4. Be sure that the plastic clips at both sides of the male connector snap over the female connector.
5. Route the diagnostic link cable through the cutouts in the sides of the base castings as illustrated in Figure 4-5.
6. Plug the 10-pin female connector at the end of the RS-422 cable into the male connector (J16) on the left side of the backplane of Unit 0. Find the arrow on the female connector. Insert the connector so that the arrow points to pin 1 (bottom, right).

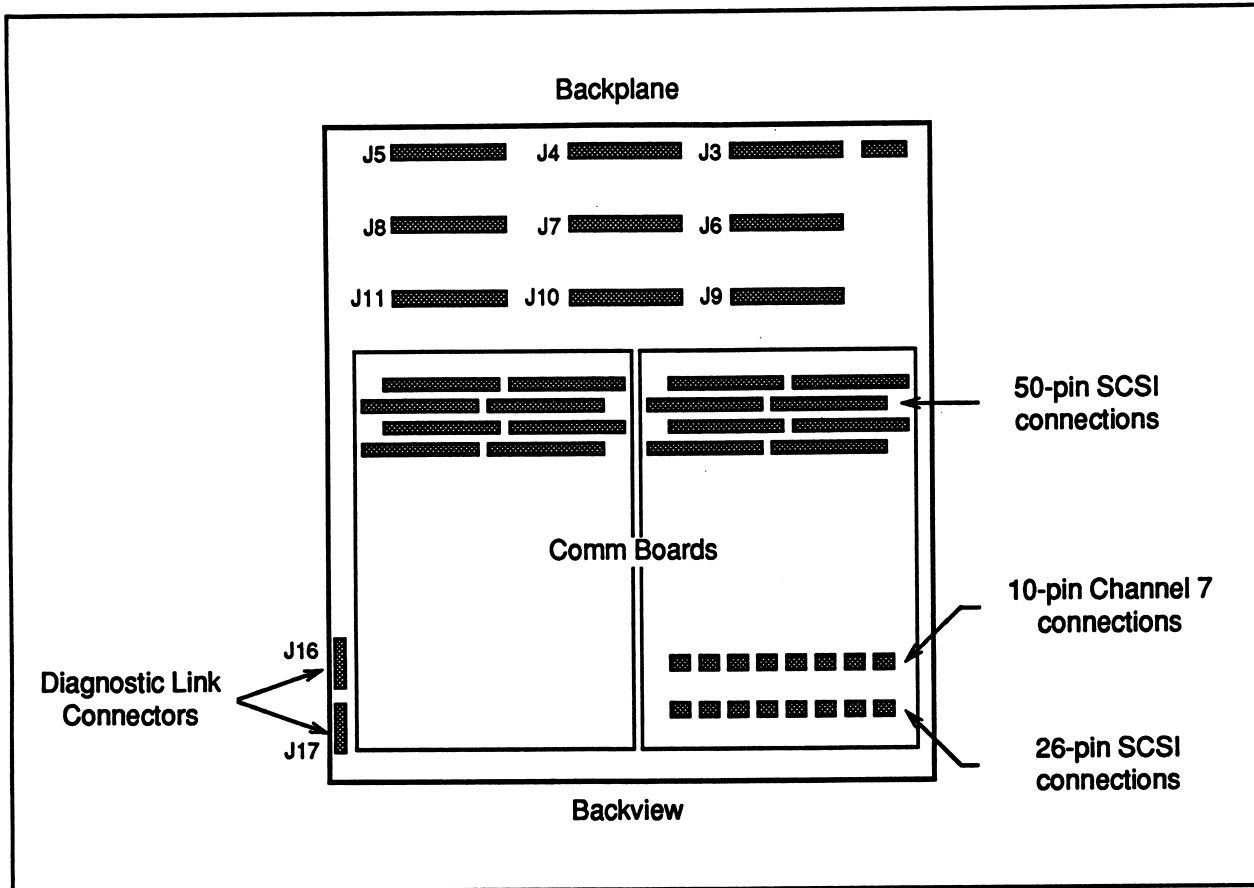

Figure 4-4. Backplane in Standard Cabinets

7. Be sure that the plastic clips at both sides of the male connector snap over the female connector.
8. Push the cable through the cut-outs in the castings into Unit 1.
9. Be sure that the plastic clips at both sides of the male connector snap over the female connector.
10. Push the cable through the cut-outs in the castings into Unit 1.
11. Find the bottom backplane for the card cage in Unit 1. Pull the cable up to it and connect the female connector at the other end of the RS-422 cable into the male connector labeled J17.
12. Be sure that the plastic clips at both sides of male connector snap over female connector.
13. Repeat this process for any other cabinets in the installation. All units, including units containing I/O nodes, must be connected by the diagnostic link.

14. Verify that the termination on the USM board is done properly. Except for the termination jumpers on the last USM board on the diagnostic cable, you should remove the termination jumpers E800-E801 and E802-E803.

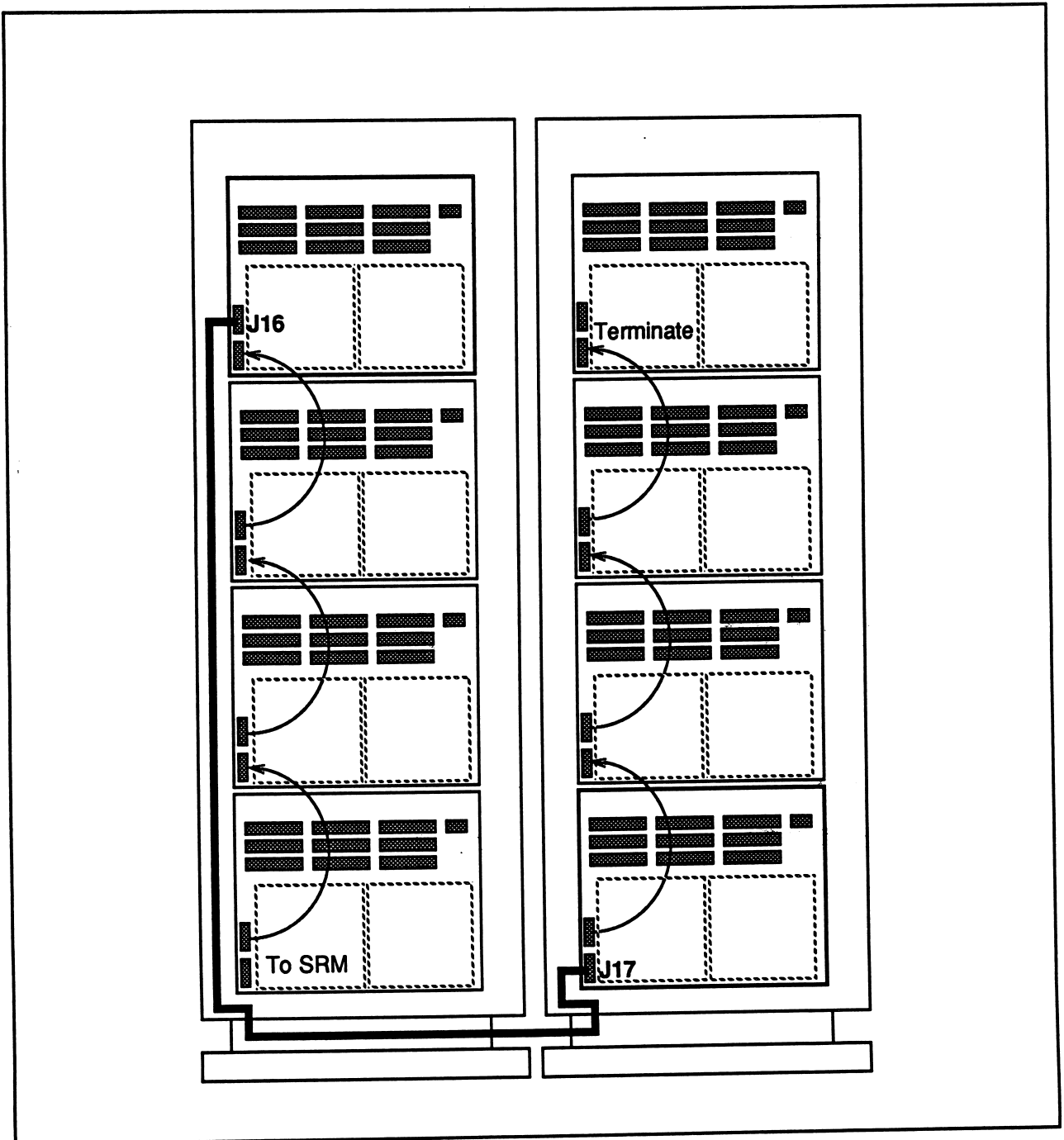

Figure 4-5. Diagnostic Cable Routing between Standard Cabinets

Installing Computational Communication Cables

If the system consists of multiple cabinets containing compute nodes, you need to install cables between the cabinets for further communications channels. These cables are 60-pin radial cables. If the system has only one computational cabinet, you do not need to install communication cables. In general, only D7 systems would require two standard cabinets. In these cabinets, Channels 4 and 5 cables are installed at the factory. You only need to install Channel 6 cables.

Use the eight 64-pin radial cables (part number 313602). Figure 4-6 shows the location of the connectors of interest on the standard cabinet backplane. Channel 6 connections use connectors J9 and J11.

1. Route the cables between the cabinets through the opening in the base castings.
2. To connect Channel 6 in a D7 two-unit system, cables always go between backplane connectors with the same designation. Channel 6 connectors are J9 and J11, so connections are made from J9 on one back plane to J9 on another backplane, and J11 to J11. Connect the backplanes directly next to one another in the two units; the top backplane in Unit 0 must be connected to the top backplane in Unit 1; the next backplane down in Unit 0 to the next backplane down in Unit 1, etc., as shown in Figure 4-6.
3. Plug the female connector on the radial cable into the appropriate male connector on the backplane (pin 1 of the cable to pin 1 of the connector). The connectors are keyed and can only be inserted one way.
4. Be sure that the plastic clips at both ends of the male connector snap over the female connector.
5. Plug the female connector at the other end of same ribbon cable into the appropriate male connector.
6. Be sure that the plastic clips at both ends of the male connector snap over the female connector.
7. Continue this process until all cables are connected.

Installing I/O Connections

I/O nodes and drives are available only in standard cabinets. If you are installing a multiple unit system, with I/O in a separate cabinet than compute nodes, you must connect communication channel 7 of each I/O node to a compute node.

The connection of I/O nodes in a standard cabinet to compute nodes in separate standard cabinets requires 10-pin internal cables (part number 313860) that run between separate units. Route them between joined cabinets similar to the way you routed Channel 6 cables. Follow this procedure.:

1. Route the I/O cables (one for each I/O board) through the cutouts between the bases of the cabinets.

2. On the communications board of the I/O cabinet, the connectors are labeled with their node numbers. In general, you do not connect an I/O node to compute node 0, because it handles the SRM communication. Beyond that, you typically connect lowest-numbered compute nodes to lowest-numbered I/O nodes. Use the pin 1 indicators on the connector as the key rather than the color of the wire on the cable. Refer to the interconnect diagram shipped with the system for precise connections.

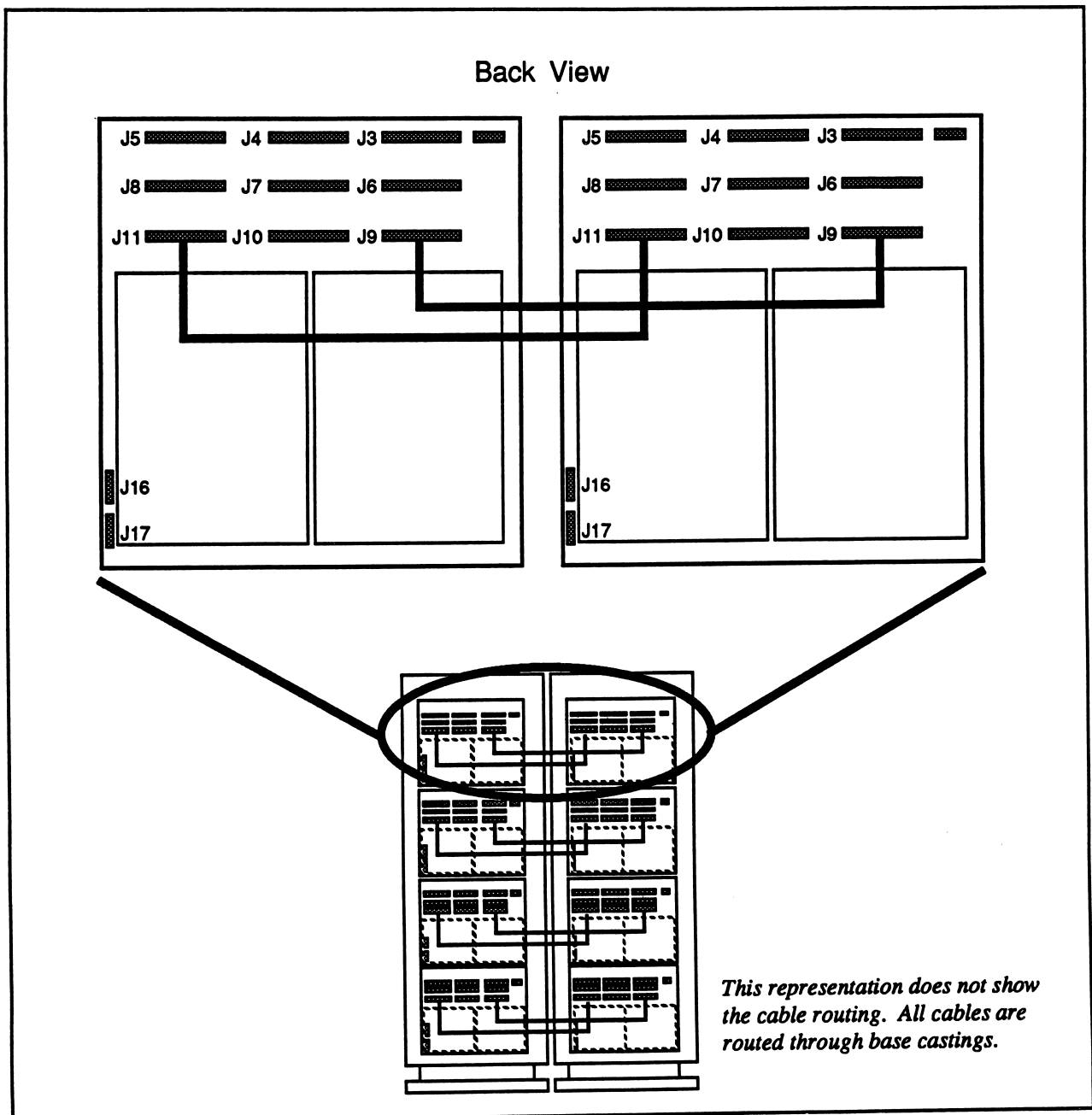

Figure 4-6. Channel 6 Cable Connections for D7 System in Standard Cabinet

3. On the communications board of the I/O cabinet, the connectors are labeled with their node numbers. In general, you do not connect an I/O node to compute node 0, because it handles the SRM communication. Beyond that, you typically connect lowest-numbered compute nodes to lowest-numbered I/O nodes. Use the pin 1 indicators on the connector as the key rather than the color of the wire on the cable. Refer to the interconnect diagram shipped with the system for precise connections.

Installing the Cable from the System Resource Manager to Unit 0

Connect the SRM direct-connect interface cable as follows:

1. Remove the I/O panel cover. It is located on the floor of the cabinet facing the back door, and is held in place with many pan-head slotted screws. Route the 15-pin end of the cable under the base of the cabinet and up through the cable run for access to the I/O panel. This routing is shown in Figure 4-7.
2. Plug the 15-pin male connector on the cable into the 15-pin connector labeled SRM on the I/O panel.
3. Screw down both ends of the male connector using a small standard screwdriver.
4. Plug the other end of the SRM cable (with the 25-pin male connector) into Slot 7 on the back of the SRM system unit.
5. Screw down both ends of the male connector on the SRM using a small straight-slot screwdriver.
6. Plug the 15-pin male connector on the cable into the 15-pin connector labeled SRM on the I/O panel.
7. Screw down both ends of the male connector using a small standard screwdriver.
8. Plug the other end of the SRM cable (with the 25-pin male connector) into Slot 7 on the back of the SRM system unit.
9. Screw down both ends of the male connector on the SRM using a small straight-slot screwdriver.

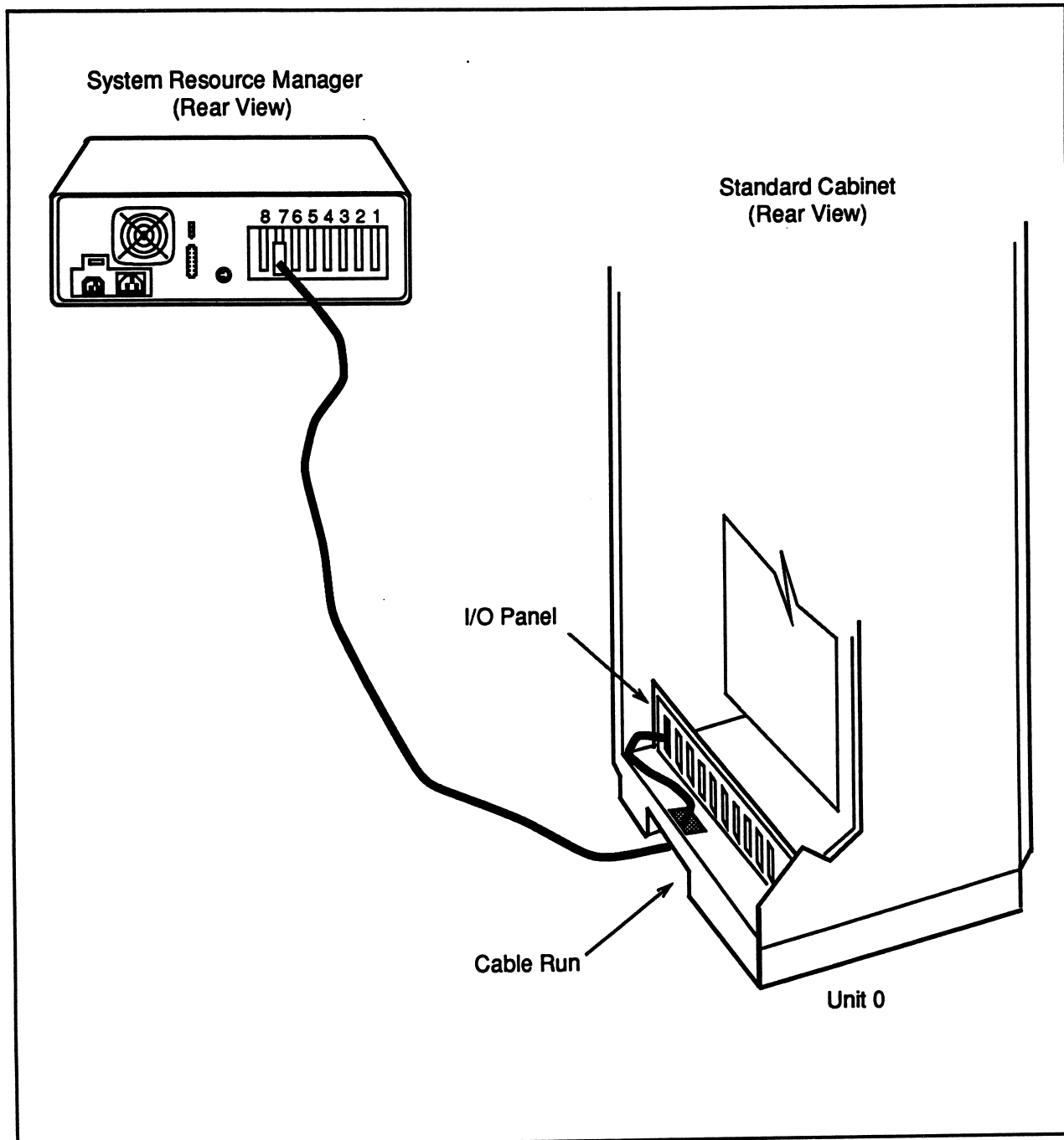

Figure 4-7. The Standard Cabinet I/O Panel and SRM Cable Routing

Attaching Front Base Filler Plates (Multiple Units Only)

Attach these plates to the front of the unit to cover the space left above the adapter cover where the bases touch.

Be sure you have the following:

- Base filler plates (1 for two units, 2 for three units, three for four units))
- #8-32 UNC by 1/4" pan-head screws with black oxide finish (4 for each filler plate)

To attach base filler plates, follow these instructions:

1. Align the base filler plate over opening above the adapter cover as shown in Figure 4-8.
2. Insert a pan-head screw into each hole.
3. Tighten the screws into place using a #1 small-tip Phillips screwdriver.
4. Repeat for remaining units.

Attaching Rear Base Filler Plates (Multiple Units Only)

Attach these plates to the back of the unit to cover the space left above the adapter cover when the bases touch.

To attach base filler plates with wedge extension, be sure you have:

- Base filler plates with wedge extension (1)
 - #8-32 UNC by 1/4" pan head screws with black oxide finish (4)
1. Align the base filler plate over opening above adapter cover. Refer to Figure 4-8.
 2. Insert a pan head screw into each hole.
 3. Tighten the screws in place using a #1 small-tip Phillips screwdriver.
 4. Repeat for remaining units.

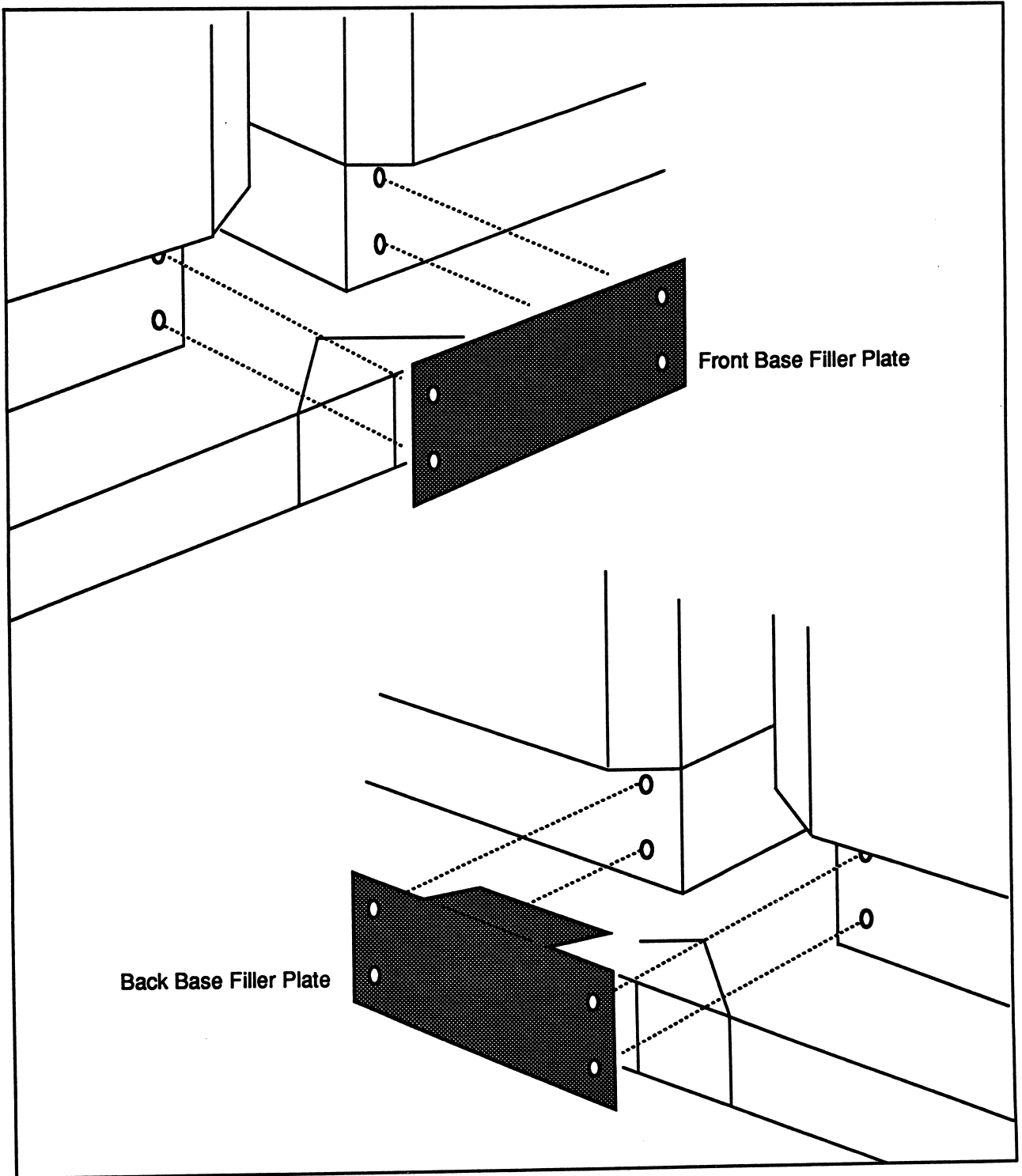

Figure 4-8. Base Filler Plates

Attaching Side Grills

Side grills are connected to the outside lower edges of outside cabinets and on both sides of a single cabinet installation

To attach side grills, be sure you have the following:

- Side grills (2)
 - #8-32 UNC by 1/4" pan head screws with black oxide finish
1. Align the side grill over the side opening at the base of the unit. The outside edges of the grill are slightly tapered. Put the wider end at the bottom.
 2. Insert a pan head screw into each hole.
 3. Tighten the screws in place using a #1 small-tip Phillips screwdriver.

Replacing the Doors

Replace the doors on any units from which they were removed. You will close the doors in a later step.

1. Align the holes in the doors with those in the L-shaped brackets (see Figure 4-1).
2. Insert and tighten the screws in reverse order from their removal. First put the screws in the top bracket (top left screw first, top right, then bottom). Next, in the bottom L-shaped brackets, insert and tighten the bottom left, bottom right, and top screw, in order. Reconnect the LED enable cable by reversing the removal procedure.

Connecting the Power Cables

Perform this procedure for all cabinets.

1. Verify that circuit breaker located at bottom back of the cabinet is in the OFF position (breaker is set to the right).
2. Plug the power cord into the cabinet.
3. Plug the power cord into the 220-volt wall receptacle. For installations abroad, refer to the section entitled "Installations Outside the United States" in Chapter 3.

Attaching the Legs to the Standard Cabinet

Attach the legs to the four outside corners of the unit(s). Make sure you have the following:

- Leg castings with levelers (4)
- Foot covers (4)
- 1/4-20 UNC by 1/2" socket head cap screws (8)

You will adjust the levelers and install the foot covers at the end of the installation.

1. Make sure the leveler is screwed all the way into the leg casting.
2. Slide the back part of the leg under the slot beneath the two holes, as in Figure 4-9.

Caution

You may need to tilt the system slightly to slide the leg in. Do not attempt to do this without help as it is extremely heavy.

3. Press the leg up and forward. The legs are spring-loaded, and will snap into the holes provided on the base.

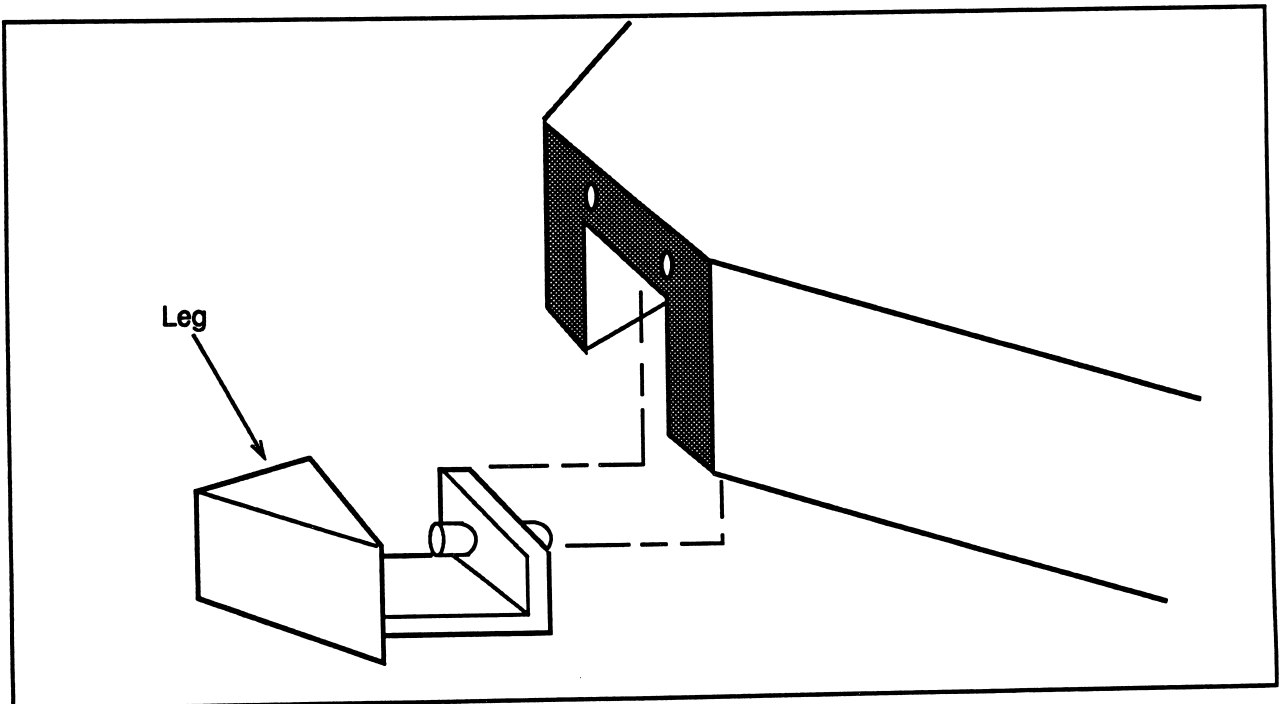

Figure 4-9. Standard Cabinet Leg

CLOSING THE CABINET DOORS

NOTE

If the system you are installing includes an optional stand-alone tape drive, install it before you close the doors. See Chapter 6 for stand-alone tape drive installation instructions.

When you have finished attaching the cabinets and installing all cables, you must shut all of the cabinet doors: rear door first, then front door.

Repeat this procedure to close the rear doors on all cabinets.

1. Replace the I/O panel cover(s).
2. Close the door. You should feel the spring-loaded latch catch the door.
3. Insert the 5/16" Allen wrench in the screw at the top right-hand side of the door. Turn it clockwise 90 degrees to fasten the door shut.
4. Go to the front of the cabinet. Replace the iPSC/2 front plate. Using a small-tip #1 Phillips screwdriver, screw in the four #4-40 UNC x 1/4" pan head screws with plastic washers that hold iPSC/2 front plate back in place.
5. Move the lever at bottom of the front door to the open position (away from the unit) until you feel the spring tension.
6. Close the front door and lock it tight by moving the lever clockwise 180 degrees toward the unit.

LEVELING THE CABINETS

After the doors are closed, level the cabinets:

1. Adjust the levelers in both the wedge adapter castings (between multiple cabinets) and the legs so that they fit snugly against the floor.
2. Place the wedge adaptor cover over the wedge adapter casting, matching the Velcro seals to secure it.
3. Place the foot covers over the legs, matching the Velcro seals to secure them.

INSTALLING OPTIONAL COMPACT CABINETS

5

INTRODUCTION

This chapter provides detailed instructions for installing iPSC/2 systems in which the compute nodes are contained in optional compact cabinets. Included are also instructions for connecting necessary cables from a standard cabinet containing Concurrent I/O hardware to optional compact cabinets. The instructions in this chapter are for new installations; Appendix A describes how to add a standard cabinet containing the Concurrent I/O hardware to a previously installed system consisting of compact computational units.

Be sure you have finished unpacking and positioning the components (as described in Chapter 2) and have installed the SRM (as described in Chapter 3) before you proceed with the installation.

The recommended order for installing the cabinets is as follows:

1. Install the cabinets with compute nodes
2. Install the I/O cabinets
3. Connect the SRM to Unit 0
4. Install the finish hardware and the legs

INSTALLING THE CABINETS

The cabinet(s) should already be in their final location. Make sure there is adequate room for you to move around them. This section describes how to install one or more standard cabinets. The general steps you need to follow are as follows:

1. Open cabinet front and back doors.
2. Join multiple cabinets.
3. Install cables that run between attached cabinets. These are referred to as internal cables in this manual. Cables that are completely contained in any single cabinet should be installed at the factory. Their installation is not covered in this manual.
4. Install external cables on I/O units.

5. Connect the SRM to cabinet 0.
6. Attach the base filler plate (multiple cabinets only).
7. Attach the legs.

Opening Front and Rear Cabinet Doors

You need to open the front and rear doors of all cabinets, whether you are installing one or multiple units.

OPENING THE FRONT DOOR

Find the lever at the bottom right of the front door. Open the front door by moving the lever counterclockwise 180 degrees.

OPENING THE REAR DOOR

To open the rear door of the optional compact cabinet, the front door must be open. With the front doors of all cabinets open, repeat this procedure on all cabinets to open the rear doors.

1. Remove the iPSC/2 front plate. Using a #1 small-tip Phillips screwdriver, unscrew the 10 screws holding it in place.
2. Set the front plate and screws aside. They will not be replaced until the end of the installation.
3. Reach through the top left opening and find the rear door lever.
4. Move the lever counterclockwise 90 degrees to release the back door as shown in Figure 5-1.

Joining Multiple Cabinets

Multiple cabinets of the same size must be joined. To do this, follow these steps (as detailed in the following sections):

1. In multiple cabinet installations, remove specified cabinet doors :
2. Connect the cabinets at the bases.

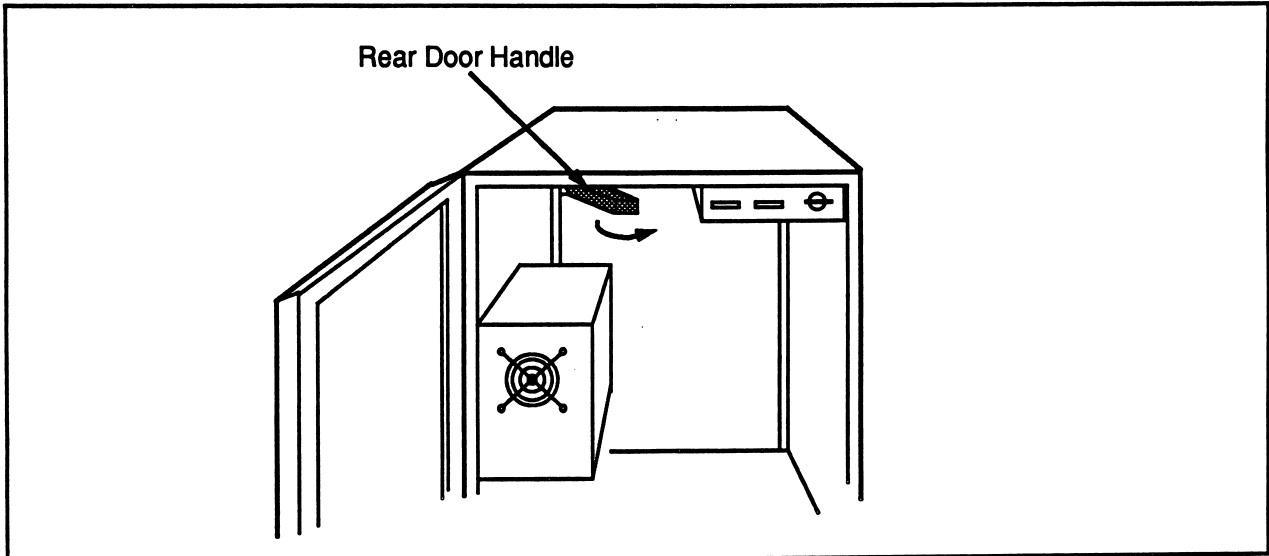

Figure 5-1. Rear Door Handle

REMOVING FRONT AND REAR DOORS

If the system consists of a single cabinet, or of a single standard cabinet and a single optional compact cabinet, you do not need to remove any doors.

When you are installing multiple cabinets of the same kind, you must remove some of the door to connect the cabinets at their bases. These guidelines describe which doors you need to remove:

- Remove the front door of the right-most cabinet.
- Remove the rear door of the left-most cabinet.
- Remove both front and rear doors of any cabinets between them.

To remove the front door of the cabinets, you need to disconnect the cable that runs from the LED board to the door. When you have unhooked this, the front and rear doors of both the standard cabinet and the optional compact cabinet are connected to the body of the cabinets in the same way. To remove the doors, follow this procedure:

1. Before you remove the door, unplug the cable from the connector located on the front door near the top hinge.
2. Locate the L-shaped brackets that hold the hinges at the top and bottom of the door, as shown in Figure 5-2.
3. Use a #2 medium-tip Phillips screwdriver to remove the three screws from the L-shaped bracket at the bottom of the door.

4. Remove the three screws from the L-shaped bracket at the top of the door in the order shown in Figure 5-2.
5. Push the door outward to release it from its hinges.
6. Set the doors and screws aside. You do not replace them until the end of the installation.

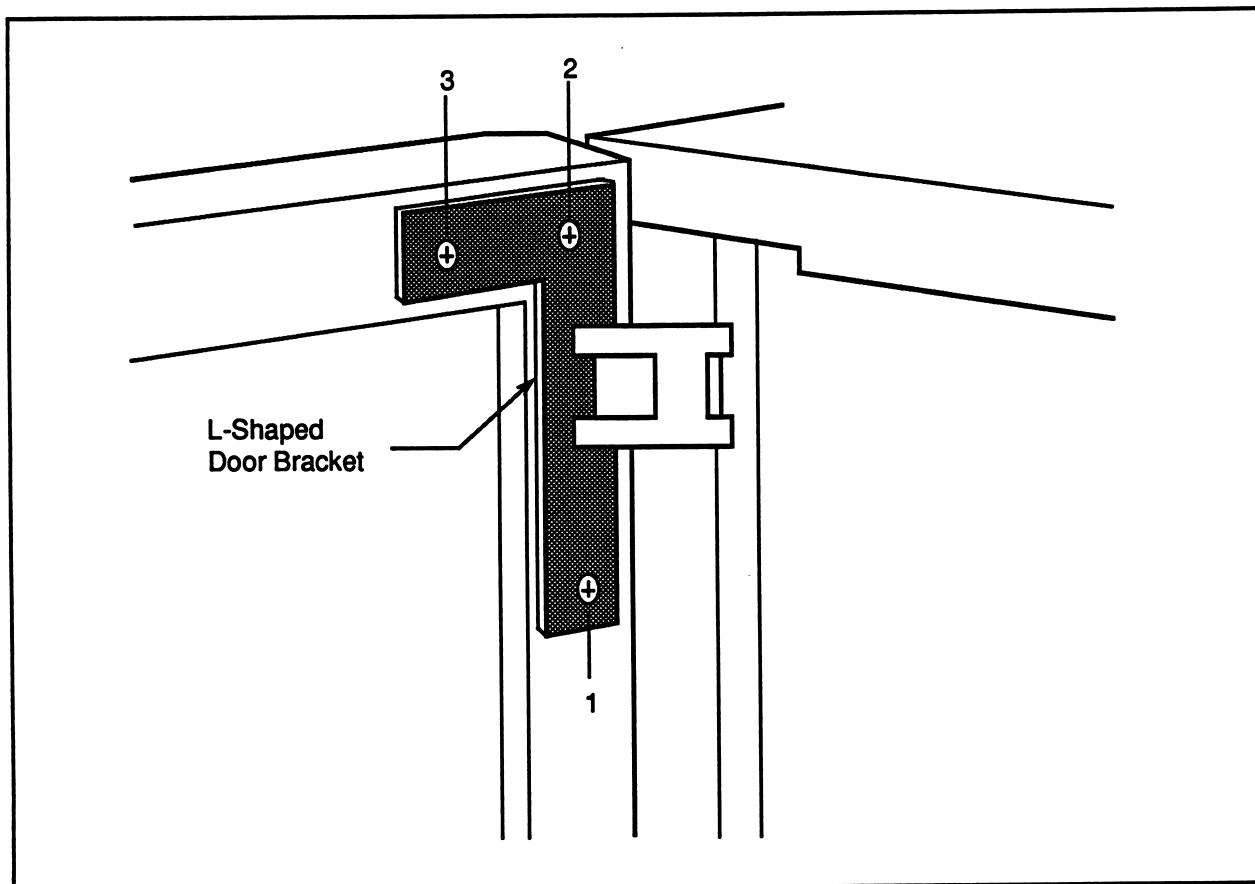

Figure 5-2. L-Shaped Door Bracket

CONNECTING THE CABINETS AT THEIR BASES

The first place you connect adjoining cabinets is the triangular space formed when the bases of two cabinets are touching, as shown in Figure 5-3. Do this on both sides of the cabinets.

Make sure you have the following items (from the accessories carton):

- Two wedge adapter castings
- Four 1/4-20 UNC by 1/2" long button head cap screws
- Two wedge adapter covers with Velcro seals

Wait until the end of the installation to adjust the levelers and install the foot covers.

1. Roll the cabinets together so they are flush against one another. The units must be in order from right to left, Unit 0 on the right, then Unit 1 on its left, etc.
2. Make sure the leveler is screwed all the way into the adapter casting.
3. Slide the tabs on the back of the wedge adapter casting up under the bases of the units, matching the two screw holes (one on each corner of the unit) as shown in Figure 5-3.
4. Insert a button head cap screw into each hole.

NOTE

Before you tighten the screws on the wedge adapter castings, position both the front and back castings and place the screws in the holes.

Start all of the screws with a 5/32" Allen wrench, then tighten them in place.

CONNECTING THE CABINETS AT THEIR TOPS

Follow this procedure once for each two adjoining units. For each two units being connected, you should have the following ready:

- Two splice plates
- Eight #4-40 UNC x 1/4" long phillips-head flat head screws

Install the splice plates as follows:

1. Locate the two holes punched in the door seal (approximately four inches from top).
2. Gently peel up the seal and the mesh from the edge of the cabinets to be joined.

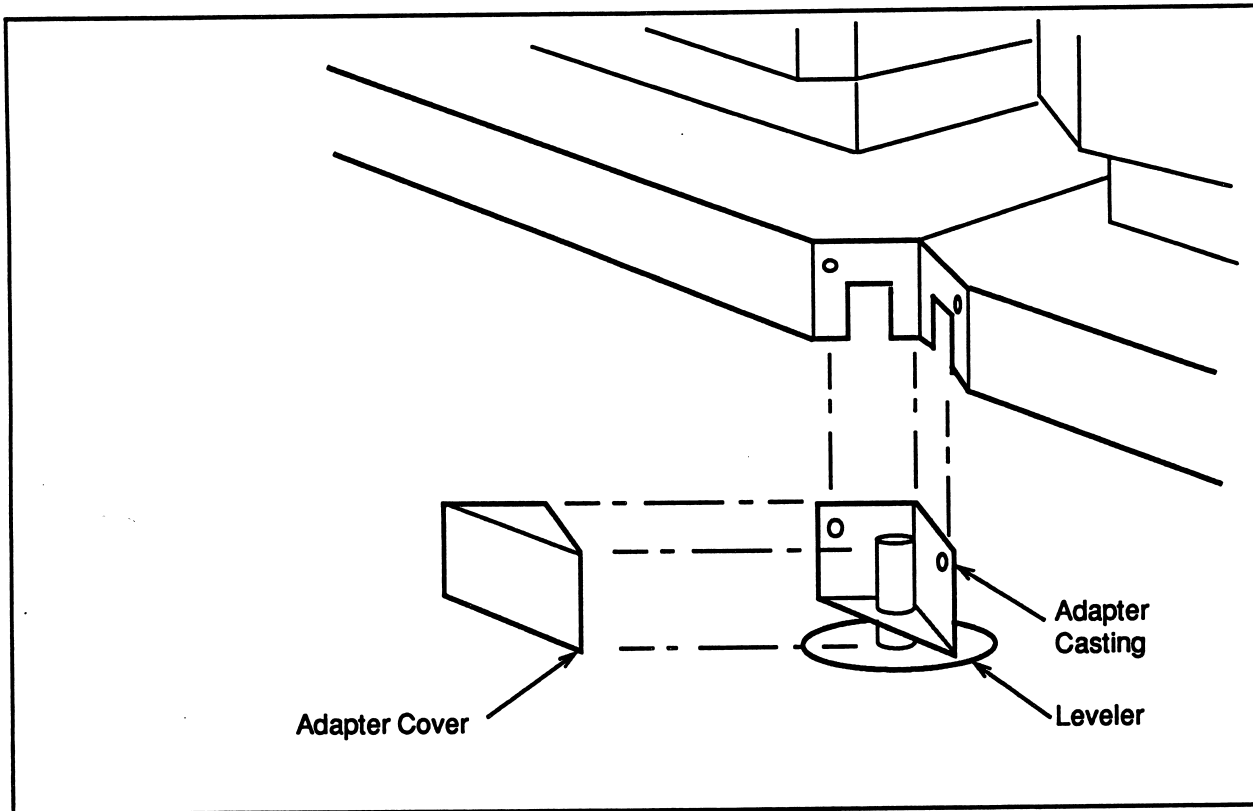

Figure 5-3. Wedge Adapter Castings and Covers

CAUTION

Do not damage or cut the seal.

3. Slide the splice plate under the door seal.
4. Align the splice plate over the four holes (two on each cabinet) as shown in Figure 5-4.
5. Insert a flat head screw into each screw hole and start each of the screws.
6. After all screws have been started, tighten both splice plate and lower wedge screws using a #1 small-tip Phillips screwdriver. Be careful not to strip the threads.
7. Press the seal back down over the splice plate

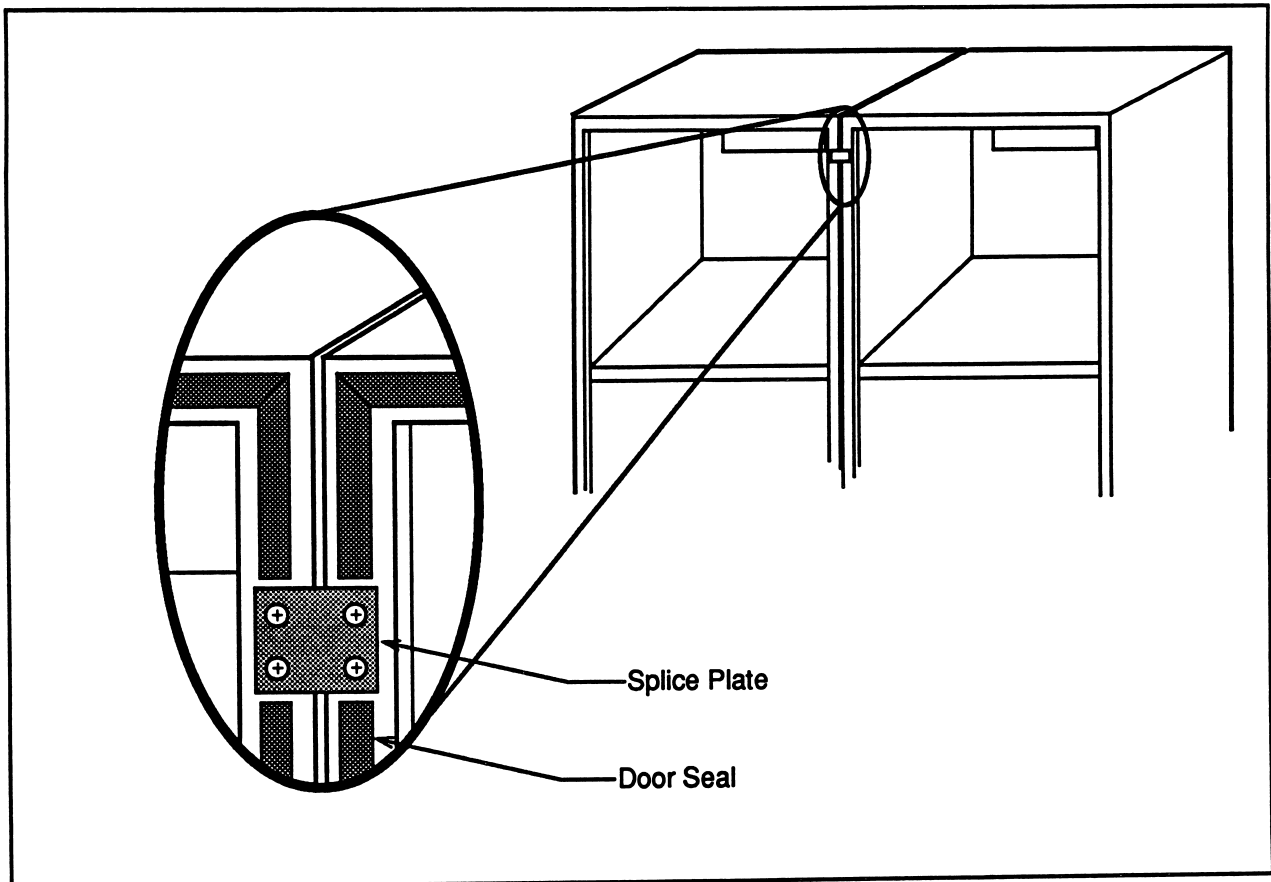

Figure 5-4. Splice Plate

Installing the RS-422 Diagnostic Link Cable in Multiple Cabinets

In multiple cabinet systems, the system accessories include one or more 10-pin ribbon cables. This cable is an RS-422 connection for the USM diagnostic channel. The following sections describe how to connect this cable.

OPTIONAL COMPACT CABINET TO OPTIONAL COMPACT CABINET

1. Plug the 10-pin female connector at either end of the RS-422 cable into the male connector (J10) at the bottom of the backplane of Unit 0. Find the arrow on the female connector. Insert the connector so that the arrow points to pin 1 (top, right).
2. Be sure that the plastic clips at both sides of the male connector snap over the female connector.
3. Push the cable through the back, side opening of Unit 1.

4. Plug the female connector at the other end of the RS-422 cable into the male connector at the bottom of the backplane of Unit 1. Cabling is shown in Figure 5-5.
5. Be sure that the plastic clips on both sides of the male connector snap over the female connector.
6. Repeat this process for any other cabinets in the installation. All units, including units containing I/O nodes, must be connected by the diagnostic link.

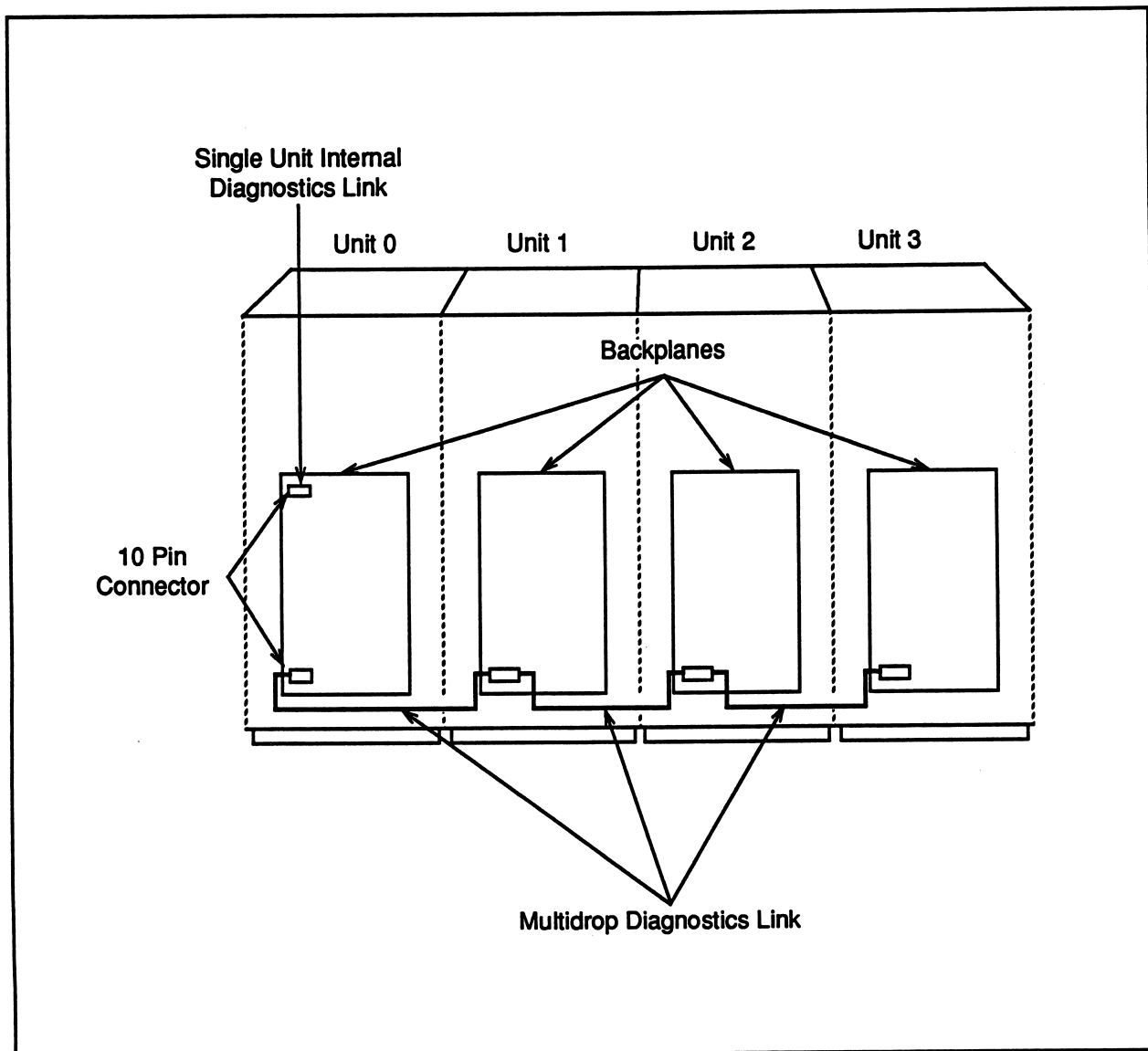

Figure 5-5. Internal Diagnostic Link Cabling

OPTIONAL COMPACT CABINET TO STANDARD I/O CABINET

This connection is only possible when optional compact cabinets contain all of the computational nodes, and the standard cabinet contains only I/O nodes and peripherals. It requires the RS-422 external cable (part number 313910).

1. After connecting the diagnostic link cable internally to all optional compact cabinets, find the 9-pin connector labeled "USM" on the I/O panel of the optional compact cabinet with the highest number, and a similar connector on the I/O panel of the standard I/O cabinet.
2. Connect the cable from the USM connector on the I/O panel of the optional compact cabinet to the USM connector on the I/O panel of the standard cabinet.
3. Verify that the termination on the USM board is done properly. Except for the termination jumpers on the last USM board on the diagnostic cable, you should remove the termination jumpers E800-E801 and E803-E802.

Installing Computational Communication Cables

If the system consists of multiple cabinets containing compute nodes, you need to install cables between the cabinets for further communication channels. These cables are 64-pin radial cables.

- For a two-unit system (D6), you should have four short cables to connect communications Channel 5.
- For a four-unit system (D7), you should have 16 cables: eight short ones for the channel 5 connection, and eight long ones for the Channel 6 connection.
- In a system consisting of a single computational unit, you do not need to install any external cables.

The following sections describe how to install all internal cables.

CHANNEL 5 CONNECTIONS (TWO- AND FOUR-UNIT SYSTEMS)

Channel 5 connections use the short 64-pin radial cables (part number 313602-001). Install each one separately:

Route the cables through the opening directly below the backplane, not through the opening between the bottom of the chassis and the base of the unit. Figure 5-6 shows the routing.

Figure 5-7 shows the cable connections from the backplane on Unit 0 to the backplane on Unit 1. The lines indicate the cable connections. Notice that the cables connect Units 0 and 1 using connectors J11 through J14. The connections shown are exactly the same for connecting Units 2 and 3 in a four-unit (D7) system.

Start with first cable from Unit 0 to Unit 1 and connect both ends to J13.

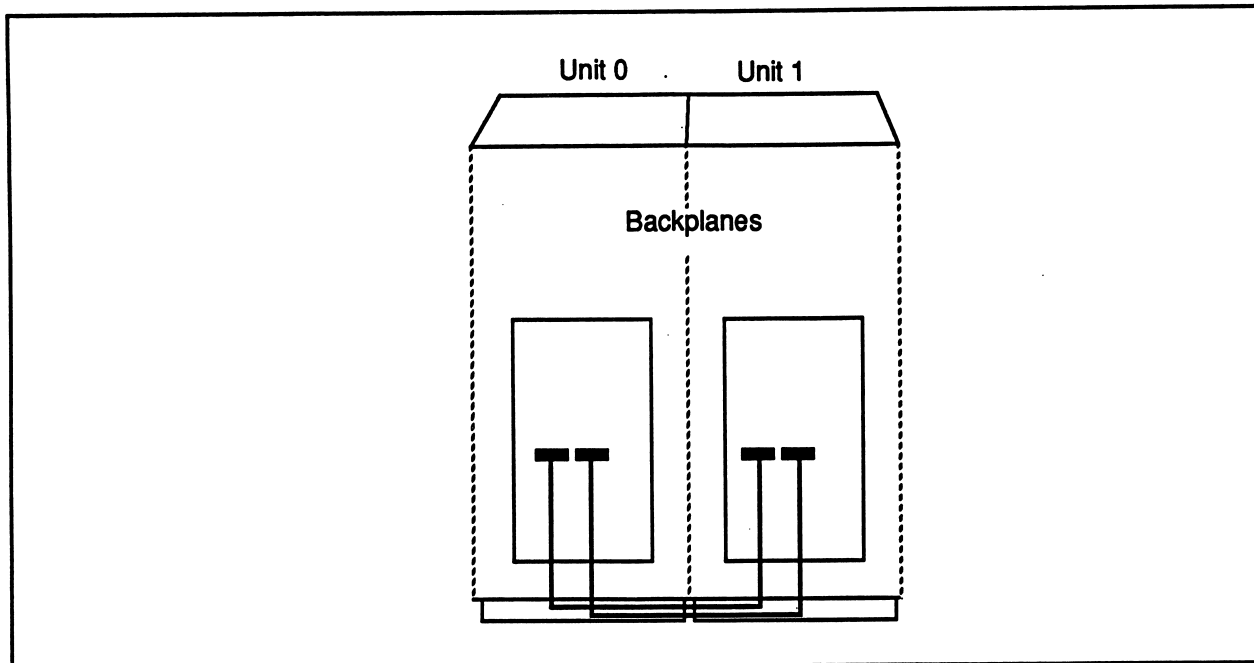

Figure 5-6. Channel 5 Cable Routing

1. Plug the female connector on the radial cable into the appropriate male connector on the backplane (pin 1 of the cable to pin 1 of the connector).
2. Be sure that the plastic clips at both ends of the male connector snap over the female connector.
3. Plug the female connector at the other end of the same ribbon cable into the appropriate male connector.
4. Be sure that the plastic clips at both ends of the male connector snap over the female connector.
5. Continue this process by taking the next cable and connecting both ends to both J14 connectors, and so on.
6. For four-unit installations (D7), connect Units 2 and 3 in exactly the same way that you connected Units 0 and 1. Refer to Figure 5-7 for the proper connectors.

CHANNEL 6 CONNECTIONS (FOUR-UNIT SYSTEMS ONLY)

In four-unit (D7) installations, you must also make communications Channel 6 connections as well as channel 5 (described in the previous section). Make sure you make the Channel 5 connections before you make the channel 6 connections.

Use the eight long 64-pin radial cables (part number 313602). Four cables connect Unit 0 to Unit 2, and four cables connect Unit 1 to Unit 3.

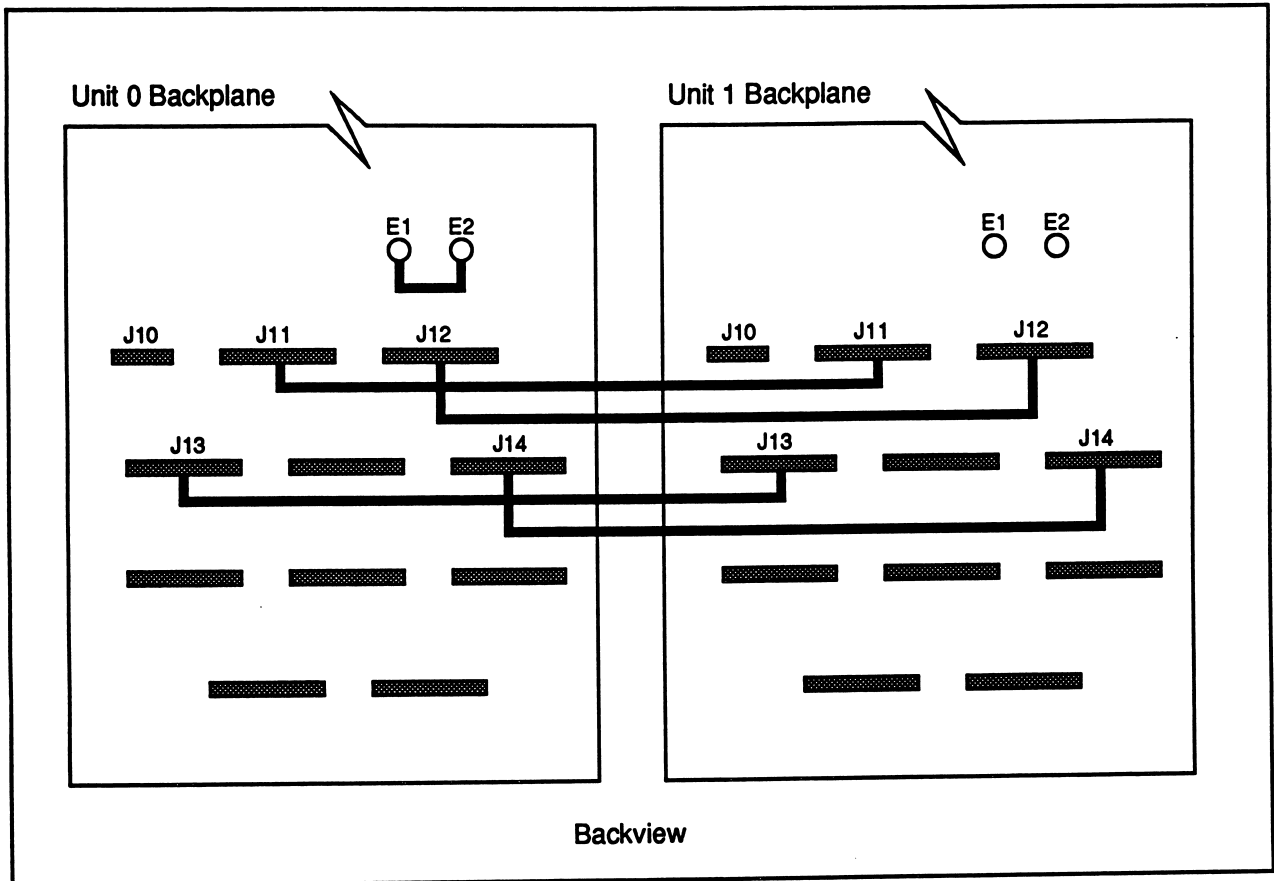

Figure 5-7. Channel 5 64-Pin Cable Connections

1. Route the cables in the same way that you routed the channel 5 cables; through the opening directly below the backplane, not through the opening between the bottom of the chassis and the base of the unit. Figure 5-8 shows the routing.
2. Figure 5-9 shows the Channel 6 connections for a D7 system. Notice that cables always go between backplane connectors with the same designation. Channel 6 connectors are J16 through J19.
3. Plug the female connector on the radial cable into the appropriate male connector on the backplane (pin 1 of cable to pin 1 of connector).
4. Be sure that the plastic clips at both ends of the male connector snap over the female connector.
5. Plug the female connector at the other end of same ribbon cable into the appropriate male connector.

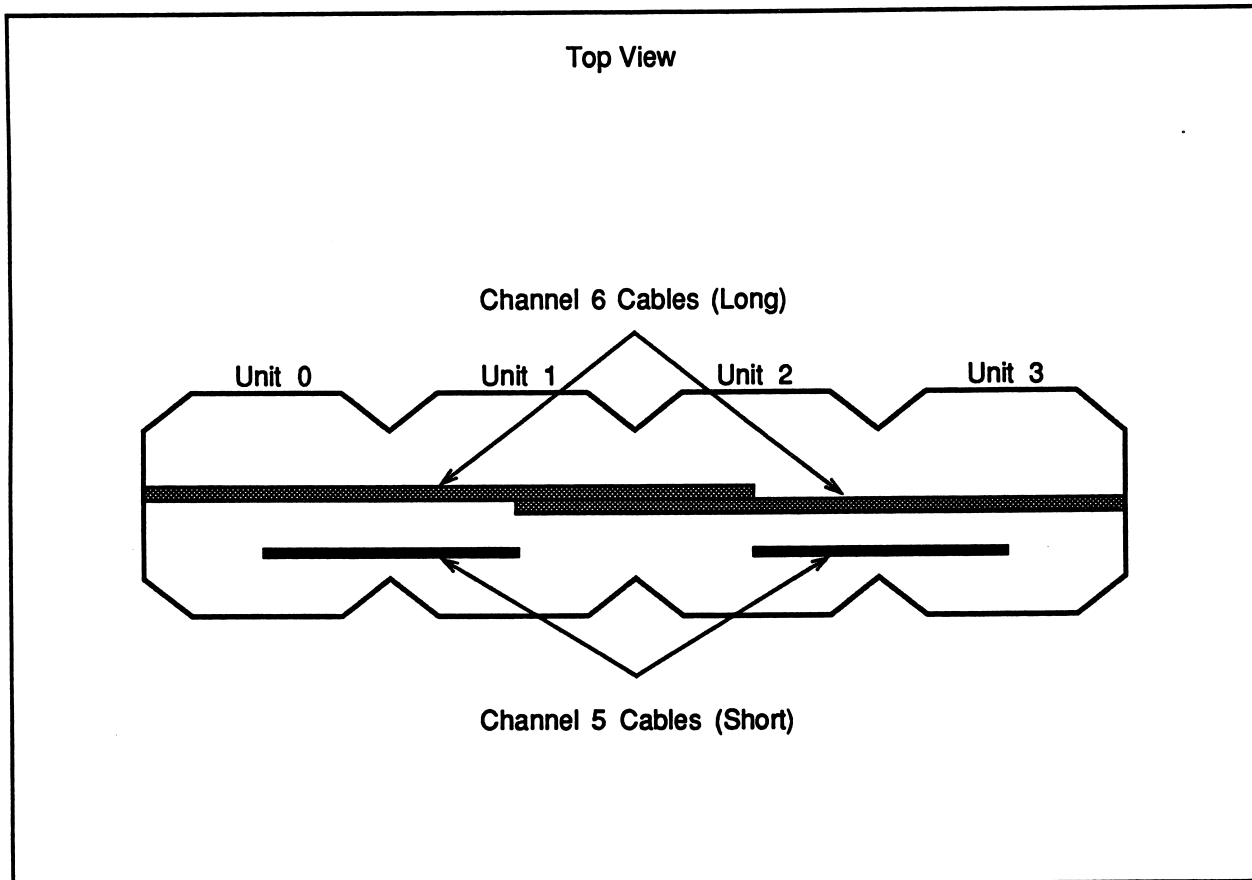

Figure 5-8. Coaxial Cable Routing

6. Be sure that the plastic clips at both ends of the male connector snap over the female connector.
7. Connect the single ground lead to the nearest grounding stud.
8. Continue this process until all cables are connected.

Connecting the Jumper Wire on Unit 0

- On the backplane of Unit 0, connect a jumper wire (part number 313947-001) from post E1 to post E2.
- Verify that E1 and E2 are not connected by jumper wires on the backplanes of computational units other than 0. If a jumper is installed in any other unit, either connect both ends of the jumper to one post or remove the jumper entirely.

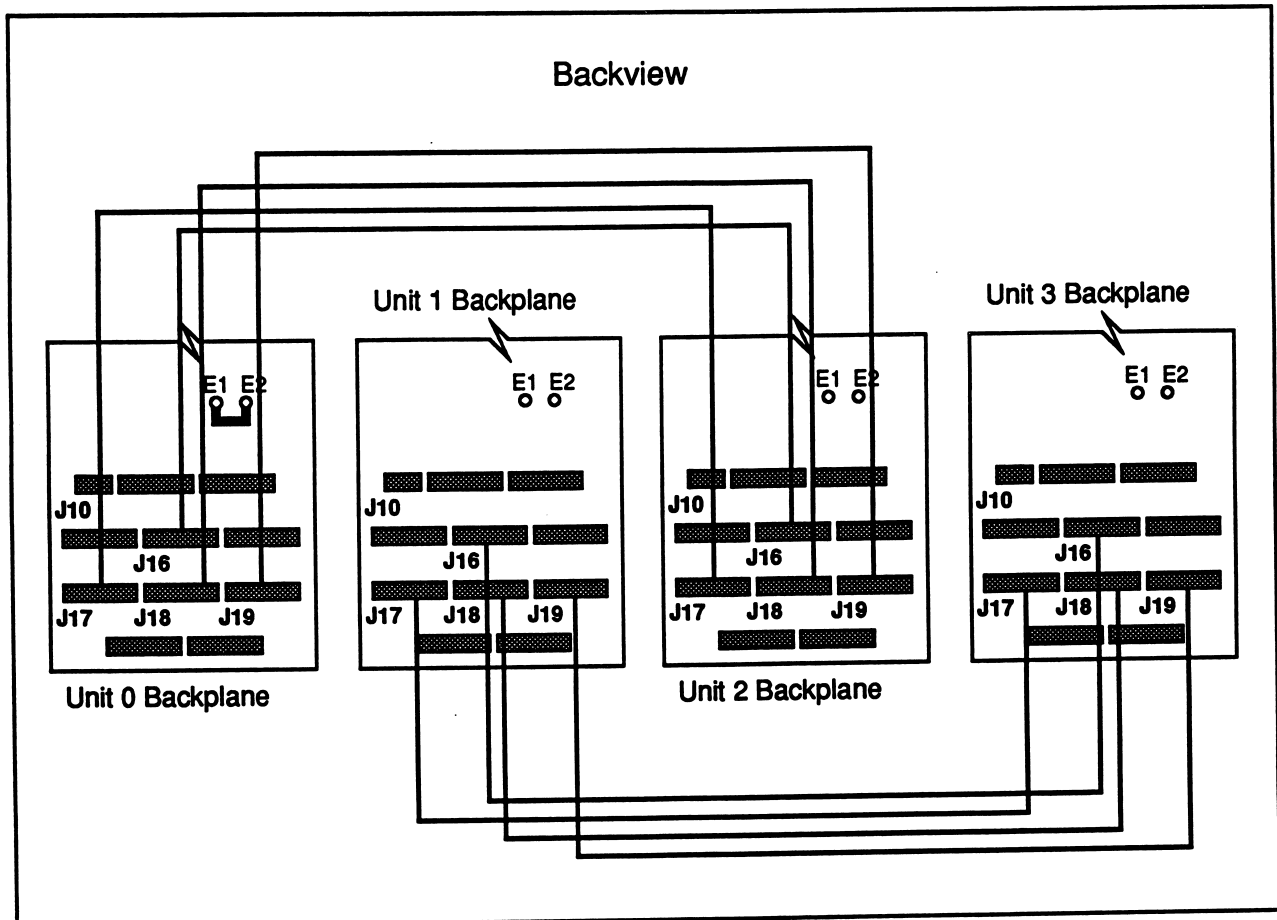

Figure 5-9. Channel 6 64-Pin System Cable Connection

Installing the AC Enable Cable in Multiple Cabinets

If you are installing a two- or four-unit system consisting of optional compact cabinets, you must install the AC enable cable between the units. Refer to Figure 5-10 and proceed as follows:

1. Plug the white female 4-pin AMP connector at either end of the AC enable cable into the male connector in the ac service in the base of Unit 0.
2. Push the cable through the middle, side opening in the base into Unit 1.
3. Plug the white female AMP connector at the other end of cable into the male connector in the AC service in the base of Unit 1.
4. If you are installing a four-unit system, repeat this process, connecting Unit 1 to Unit 2, and Unit 2 to Unit 3.

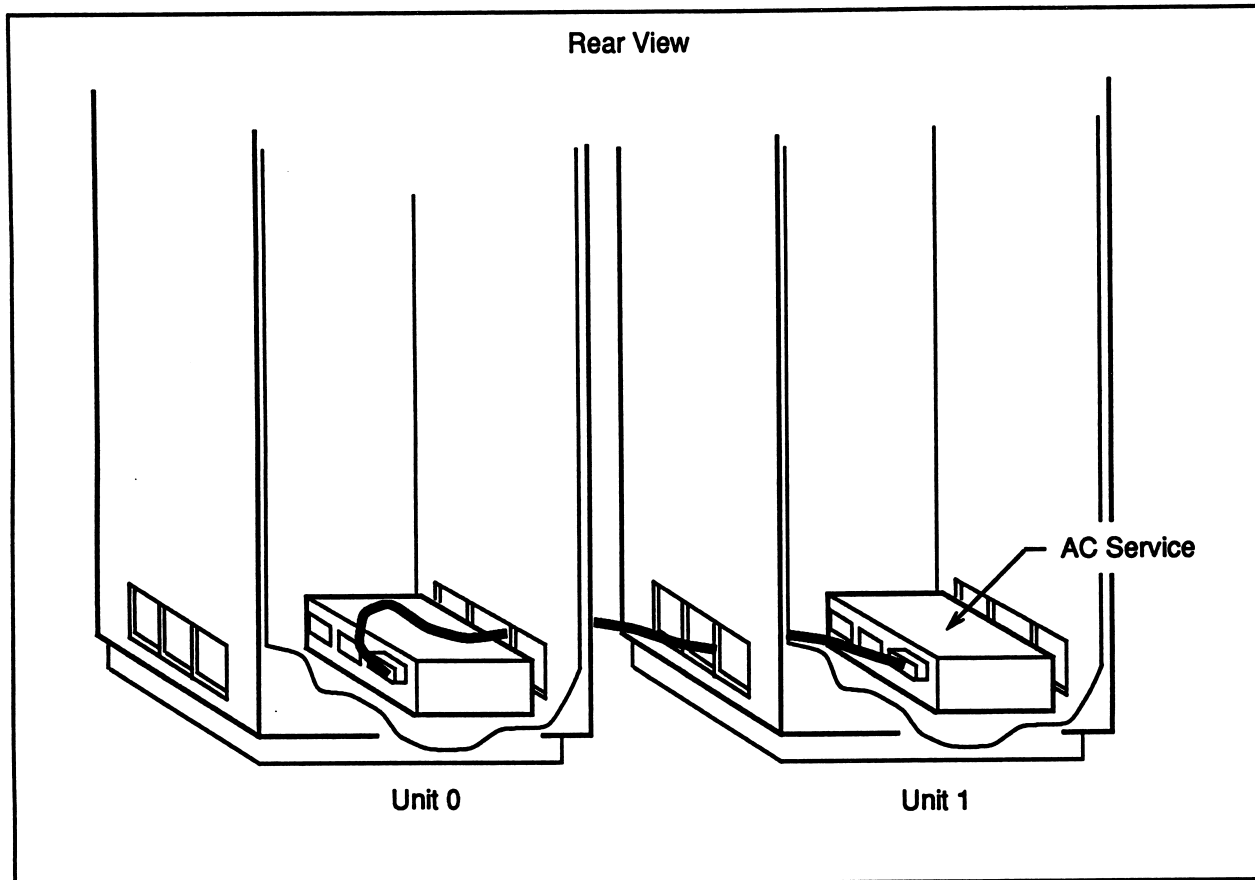

Figure 5-10. AC Enable Cable Connection for Optional Compact Cabinets

Installing I/O Connections

I/O nodes and drives are available only in standard cabinets. You must connect communication Channel 7 of each I/O node to a compute node. This requires external cables (part number 313819). The backplane connections in the optional compact cabinet allow you to connect I/O nodes to one of every four compute nodes, starting with Node 2 (2, 6, 10, 14, 18, 22, etc.).

Typically, you connect the lowest-numbered I/O node to the lowest-numbered available compute node. For example, if you were connecting four I/O nodes (0-3) to compute nodes in Unit 0, you would connect I/O Node 0 to compute Node 2, I/O Node 1 to compute Node 6, I/O Node 2 to compute Node 10, and I/O Node 3 to compute Node 14.

Follow this procedure for the connection:

1. Remove the L-shaped plate covering the I/O panel of the standard cabinet. This is held in with many straight-slot pan-head screws.

2. Route the external cables through the cable run in the bottom of the I/O panel box, and then along (or under) the floor (depending upon the site preparation) to the computational unit(s) they are to be connected to.
3. The I/O panel on the optional compact cabinet is on the outside bottom of the back of the cabinet. It is numbered left to right. To connect the lowest numbered I/O connection to the lowest numbered compute connection, connect the right-most connector on the standard cabinet I/O panel to the left-most connector on the optional compact cabinet I/O panel, etc.

Installing the Cable from the System Resource Manager to Unit 0

Connect the SRM direct-connect interface cable as follows:

1. Plug the 25-pin male connector on the SRM cable into Slot 7 on the back of the SRM system unit. Refer to Figure 5-11.
2. Screw down both ends of the male connector using a small straight-slot screwdriver.
3. Plug the 25-pin male connector on the cable only into the unlabeled female connector located in the I/O panel at the bottom rear of the unit.
4. Screw down both ends of the male connector using a small straight-slot screwdriver.

Attaching Front Base Filler Plates (Multiple Units Only)

Attach these plates to the front of the unit to cover the space left above the adapter cover when the bases touch.

Be sure you have the following:

- Base filler plates (1 for two units, 2 for three units, 3 for four units)
- #8-32 UNC x 1/4" pan-head screws with black oxide finish (4 for each filler plate)

To attach base filler plates, follow this procedure

1. Align the base filler plate over opening above the adapter cover as shown in Figure 5-12
2. Insert a pan-head screw into each hole.
3. Tighten the screws into place using a #1 small-tip Phillips screwdriver.
4. Repeat if you are installing more than two units.

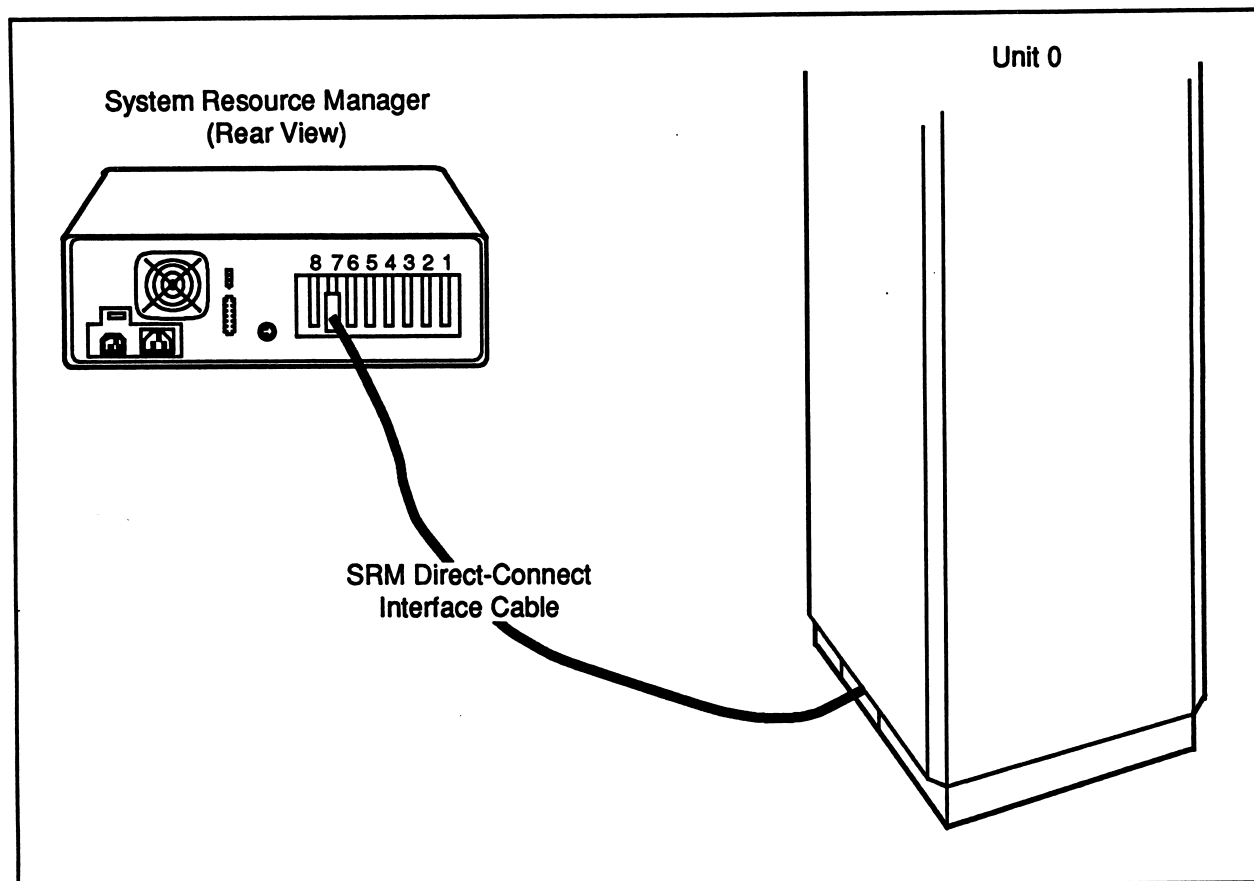

Figure 5-11. Cabinet to System Resource Manager Cable Connections

Attaching Rear Base Filler Plates (Multiple Units Only)

Attach these plates to the rear of the unit to cover the space left above the adapter cover where the bases touch.

Be sure you have:

- Base filler plates with wedge extension (1 for two units, 2 for three units, 3 for four units)
- #4-40 UNC x 1/4" pan head screws with black oxide finish (4)

To attach base filler plates with wedge extension, follow this procedure

1. Align the base filler plate over opening above adapter cover. Refer to Figure 5-12.
2. Insert a pan head screw into each hole.
3. Tighten the screws in place using a #1 small-tip Phillips screwdriver.
4. Repeat if you are installing more than two units.

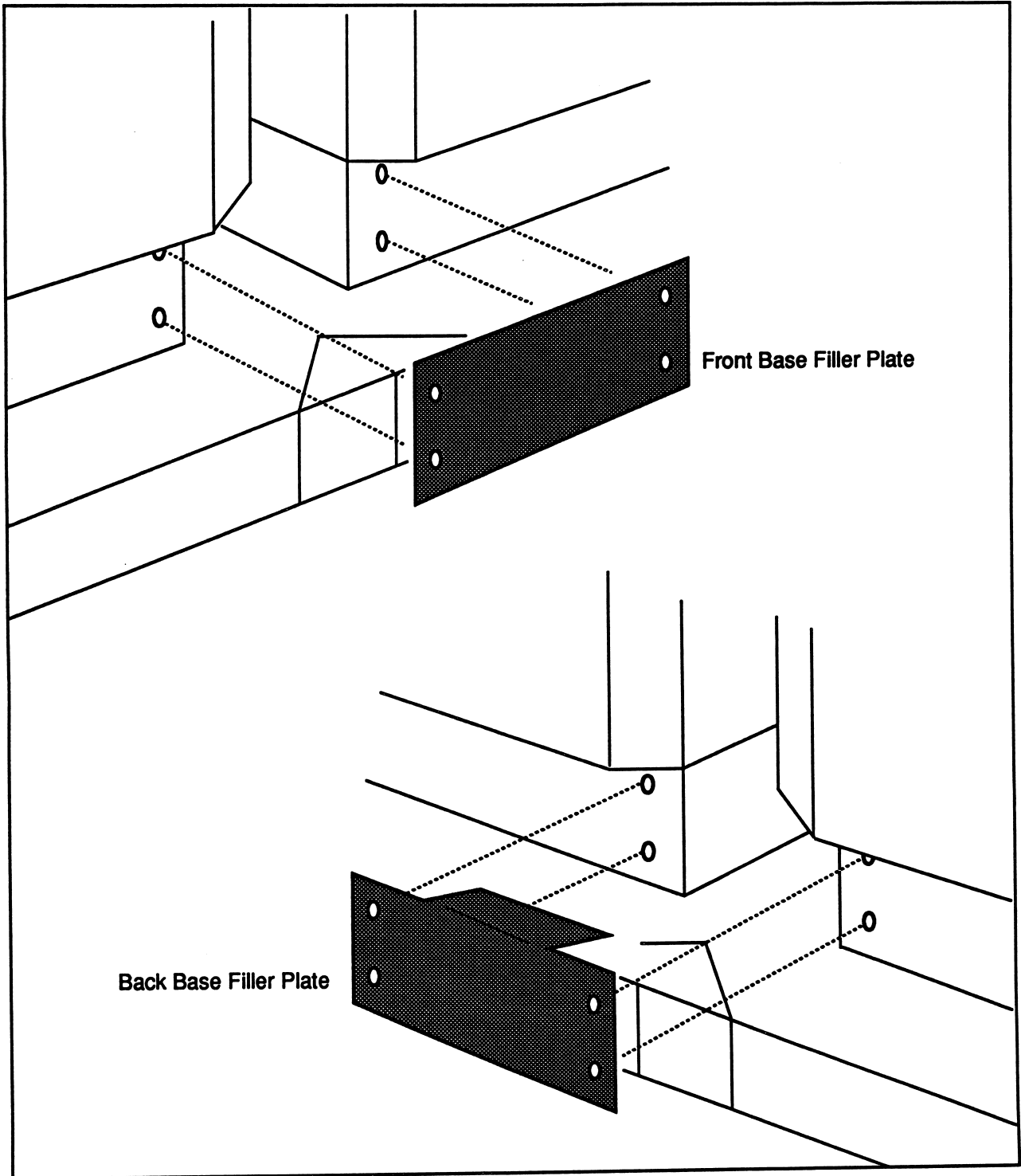

Figure 5-12. Base Filler Plates

Attaching Side Grills

Side grills are connected to the outside lower edges of outside cabinets and on both sides of a single cabinet installation.

Be sure you have the following:

- Side grills (2)
- #8-32 UNC by 1/4" pan head screws with black oxide finish (8)

To attach side grills, follow this procedure:

1. Align the side grill over the side opening at the base of the unit. The outside edges of the grill are slightly tapered. Put the wider end at the bottom.
2. Insert a pan head screw into each hole.
3. Tighten the screws in place using a #1 small-tip Phillips screwdriver.

Replacing the Doors

Replace the doors that were removed. You will close the doors in a later step.

1. Align the holes in the doors with those in the L-shaped brackets (see Figure 5-2).
2. Insert and tighten the screws in reverse order from their removal. First put the screws in the top bracket (top left screw first, top right, then bottom). Next, in the bottom L-shaped brackets, insert and tighten the bottom left, bottom right, and top screw, in order.
3. Reconnect the LED enable cable by reversing the removal procedure.

Connecting the Power Cables

Perform this procedure for all cabinets:

1. Verify that the circuit breakers located at bottom back of all cabinets are in the OFF position (breaker is set to right).
2. Be sure that the keyswitch at the top front of the unit is in the horizontal (OFF) position. (Standard cabinets do not have a keyswitch.)
3. Plug the power cord into the cabinet.
4. Plug the power cord into the 220-volt wall receptacle. For installations abroad, refer to the section entitled "Installations Outside the United States" in Chapter 3.

Attaching the Legs

Attach the legs to the four outside corners of the unit(s). Make sure you have the following:

- Leg castings with levelers (4)
- Foot covers (4)
- 1/4-20 UNC x 1/2" socket head cap screws (8)

You will adjust the levelers and install the foot covers at the end of the installation.

1. Make sure the leveler is screwed all the way into the leg casting.
2. Align each leg casting over the two holes on each corner of the unit by sliding the tab on the leg up into the base, as illustrated in Figure 5-13.
3. Insert a socket head cap screw into each hole.
4. Tighten the screws in place using a 3/16" Allen wrench. Be careful not to strip the threads.

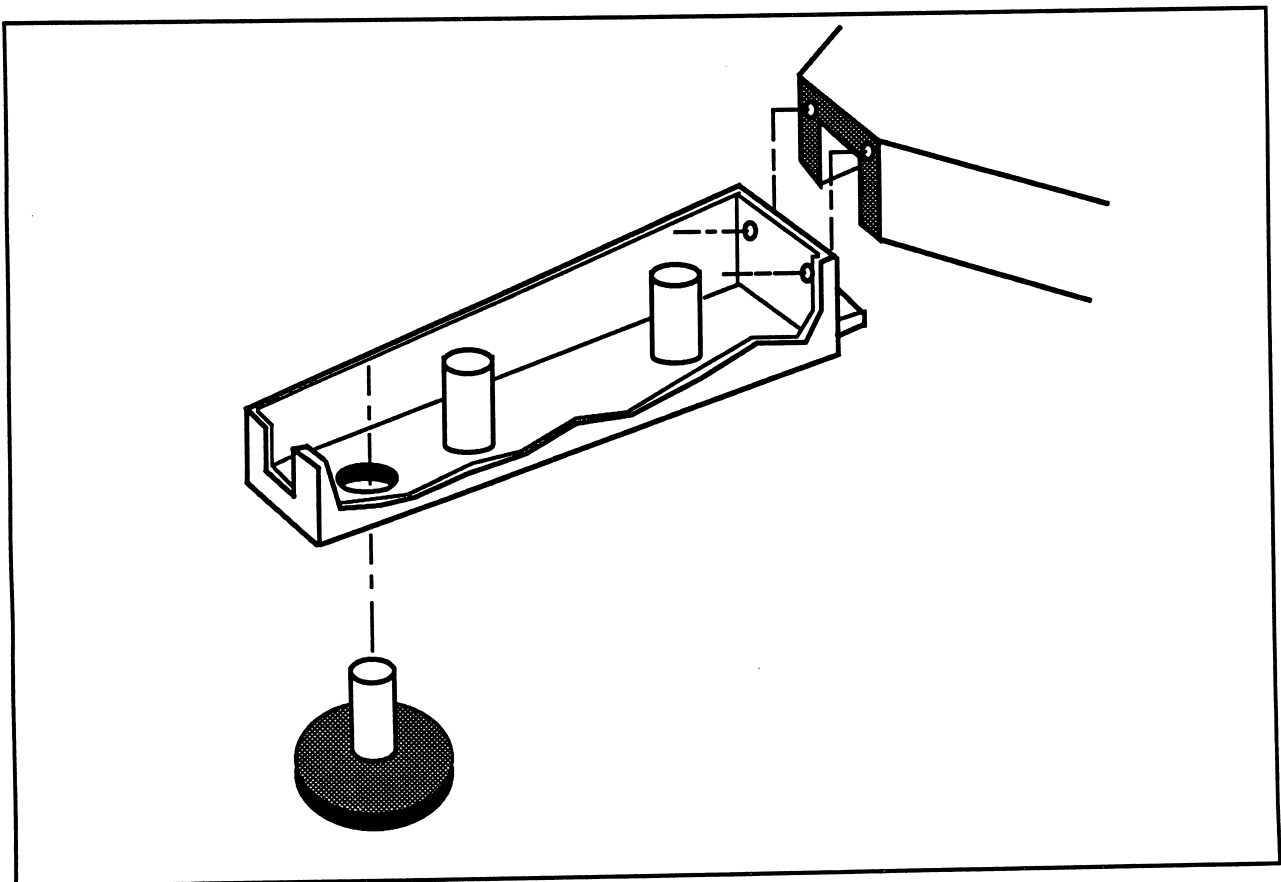

Figure 5-13. Compact Cabinet Leg

INSTALLING THE OPTIONAL STAND-ALONE TAPE DRIVE **6**

INTRODUCTION

The general procedure for installing the optional stand-alone tape drive is as follows:

1. Position the tape drive cabinet near the standard I/O cabinet to which it is to be connected, leaving access room (at least 3 feet) on the right side of the tape drive and at its front and back.
2. Expose the tape drive's SCSI connector.
3. Route the cable.
4. Connect the cable to the tape drive and the iPSC/2 I/O panel.

INSTALLING THE TAPE DRIVE

All peripheral devices (hard disks, internal tape drives, and stand-alone tape drives) in the iPSC/2 are driven by I/O nodes. Therefore, the stand-alone tape drive must be connected directly to an I/O node.

When a customer orders a new system that includes a stand-alone tape drive, the standard cabinets containing I/O nodes to which the tape drive(s) are connected will have a special I/O panel with 13 standard cutouts and two cutouts for 50-pin connectors. This I/O panel is shown in Figure 6-1.

Within the cabinet, a connector from the I/O node terminates in a 50-pin male connector installed in one of the 50-pin cutouts. If two tape drives are to be connected to two separate I/O nodes in the same cabinet, both cutouts may have connectors installed in them.

Before installing the cable, open the top lid of the tape drive cabinet. Find the slide catch in the indented section in the front center of the lid, and move the catch to the left to release it. Lift the lid up and remove the packing between the right side of the tape drive mechanism and the wall of the cabinet. Close the lid.

To install the drive, you must connect the external 50-pin cable (part number 314326) from the connector on the I/O panel of the iPSC/2 standard cabinet to the proper connector on the tape drive, following the procedure described in the next section.

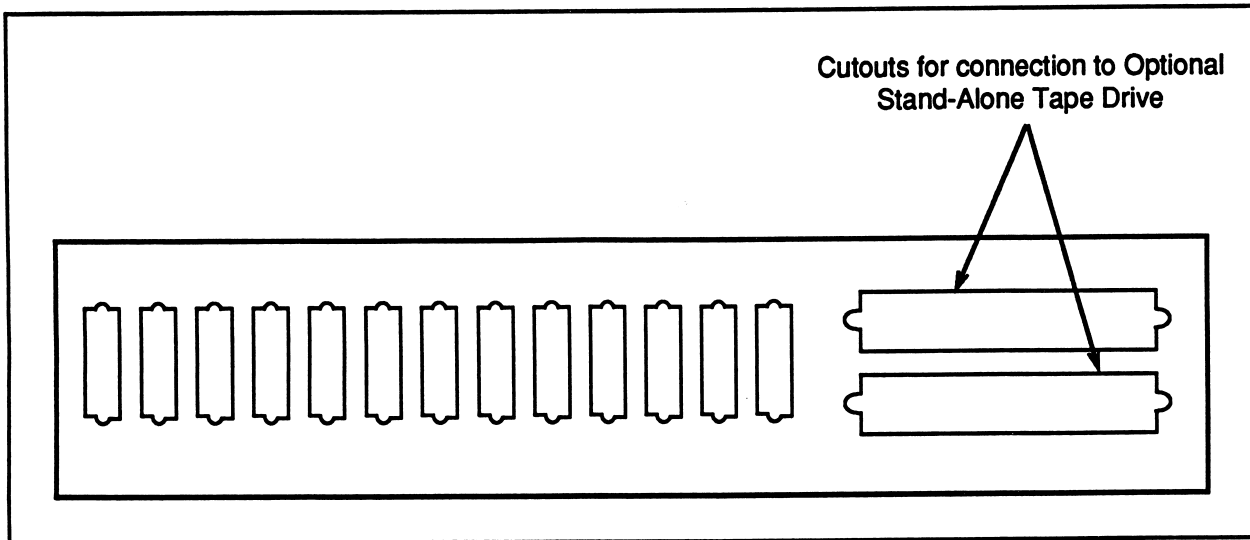

Figure 6-1. I/O Panel for Stand-Alone Tape Drive Connection

Routing and Connecting the Cable

1. If the cover over the I/O panel in the iPSC/2 is not removed, remove it by taking out all of the screws holding it down. When it is removed, you can see both the I/O panel and the cable run that opens to the bottom of the system.
2. Route one end of the cable up through the cable run in the iPSC/2 cabinet and the other end through the cable run in the base of the tape drive cabinet.
3. Connect the female connector on the other end of the cable to the male connector in the iPSC/2 standard cabinet's I/O panel.
4. Connect the female connector on the cable to the 50-pin male connector just under the base at the center rear of the tape drive cabinet. This completes the installation.

INTRODUCTION

This chapter outlines how to apply power to the system and run the confidence test on each component. Finally, it explains how to run the Cube Diagnostic Program (CDP).

APPLYING POWER

NOTE

For installations outside the United States, before you apply power be sure that you have the proper power plugs for the SRM monitor, system unit, and cabinets. See the section entitled "Installations Outside the United States" in Chapter 3 and follow the instructions strictly.

Perform these steps in the order given to apply power to the system. A confidence test is run automatically when the iPSC/2 system is turned on. If you encounter any problems performing the following procedures, call iSC Customer Support:

1-503-629-7777 (Customer Support Hotline in Oregon)

1-800-421-CUBE (Customer Support Hotline outside of Oregon)

(44)793 696 619 (in England)

Your local Intel Sales Office (in Europe)

support@isc.intel.com (csnet address)

...!omepd!intelisc!support (uucp address)

Applying Power to the SRM Monitor

Turn on the monitor by pushing the ON/OFF switch located on the front of the video module.

If the SRM is plugged into the wall socket, the green LED located on the lower front should come on. If it does not, first verify that the AC power cord is plugged into the SRM system unit, and if it is, call iSC Customer Support.

If the SRM is plugged into the SRM system unit with the AC jumper cord, the LED will not light until the SRM system unit is turned on.

If you need more information, refer to the monitor's User's Manual.

Applying Power to the SRM System Unit

Turn on the SRM system unit by pushing the ON/OFF switch up to the ON position. The ON/OFF switch is located on the right side. The following things should occur:

1. The green power indicator, located on the front of the unit, should light and the red power indicator should flash. If not, first verify that the AC power cord is plugged in. If it is, and the unit still does not come on, call iSC Customer Support.
2. The monitor screen should be illuminated and the cursor should appear. If it does not, first verify that the monitor power cord is plugged into the SRM system unit. If it is and the monitor still does not come on, call iSC Customer Support.
3. Make sure the screen brightness is set properly by adjusting the brightness control on the back of the monitor.
4. The Power-On Self-Test (POST) is automatically executed. POST checks the system microprocessor, the keyboard, the display, system memory, and most peripheral devices connected to the SRM system unit each time you turn on the system. Refer to the *SYP301 Installation and User's Guide* for more information about POST. If you receive error messages, first refer to Appendix B in the *SYP301 Installation and User's Guide*. If you cannot solve the problem, call iSC Customer Support.
5. When this test is finished running, UNIX is loaded automatically. You should see the message:

```
The system is coming up. Please wait
```

The system is booted when you see the prompt: **Console login:**. If you encounter any problems, refer to the *SYP301 Installation and User's Guide*.

Applying Power to Standard Cabinets

1. Move the circuit breaker (located at bottom back of all units) to the left (the ON position). Do this for each cabinet. This supplies the system with AC power.
2. Verify that the fans come on. If not, check the following:
 - A. Make sure the AC power cord is plugged into the power receptacle.
 - B. Check the cabinet circuit breaker, or breaker box.
 - C. Open the rear door and check to be sure all power plugs in firmly in place.
 - D. If you can confirm that the system is receiving power but no power indicators are lit, call iSC Customer Support.
3. The node Confidence Test (NCT) is automatically executed. Verify that the red and green indicator lights on the node boards come on as NCT is executed in parallel on all nodes. The green light stays on when a node passes the test successfully (except for the USM board) and the red light goes off.
4. If the red indicator is lit on only one node board, turn the power switch on that cabinet off, wait 10 seconds, then turn it back on. If this does not correct the problem, call iSC Customer Support.
5. If the red indicator light is on in more than one node board:
 - A. Turn the breaker for the cabinets in which those node boards reside, wait 10 seconds, then it turn back on.
 - B. If it is still lit, run the CDP. (See the *iPSC®/2 System Administrator's Guide* for more information on the CDP.) Call iSC Customer Service with the results.
6. If neither the green nor red indicator is lit, call iSC Customer Support.
7. If the red indicator on any node board is blinking, call iSC Customer Support.

Applying Power to Optional Compact Cabinets

1. Move the circuit breaker (located at bottom back of all units) to the left (ON position). This supplies the system with AC power.
2. Verify that the amber (AC) indicator (located at the top front of all units) lights. If not, check the following:
 - A. Make sure the AC power cord is plugged into a power receptacle.
 - B. Check cabinet circuit breaker, or breaker box.
 - C. Make sure fans are running.
 - D. If you can confirm that the system is receiving power but no power indicators are lit, call iSC Customer Support.

3. Turn the keyswitch (located at the top front of all units) to the vertical (ON) position. This supplies the system with DC power.

NOTE

In systems consisting of multiple compact cabinets, only one keyswitch needs to be turned on to supply power to the rest of the system. If more than one keyswitch is turned on for any reason, you must turn the keyswitch off on every unit to turn the system power off.

4. Verify that the green (DC) indicator (located at top front of all units) lights. If not, check the cube circuit breaker, or breaker box. If it is in the proper position and the indicator still does not light, call iSC Customer Support.
5. The node Confidence Test (NCT) is automatically executed. Verify that the red and green indicators on the node boards light as NCT is executed in parallel on all nodes. The green light stays on when a node passes the test successfully (except for the USM board) and the red light goes off.
6. If the red indicator is lit on only one node board:
 - A. Turn the keyswitch to the horizontal (OFF) position, wait 10 seconds, then turn it back on.
 - B. If the indicator is still lit, call iSC Customer Support.
7. If the red indicator light is on in more than one node board:
 - A. Turn the keyswitch to the horizontal (OFF) position, wait 10 seconds, then it turn back on.
 - B. If the indicator is still lit, run CDP. (See the *iPSC®/2 System Administrator's Guide* for more information on the CDP.) Call iSC Customer Service with the results.
8. If neither the green nor the red indicator is lit, call iSC Customer Support.
9. If red indicator light on any node board is blinking, call iSC Customer Support.

CUBE DIAGNOSTIC PROGRAM

The Cube Diagnostic Program (CDP) checks the communication links between the cabinet(s) and the SRM as well as between all of the nodes. CDP also checks optional hardware installed in the system. CDP includes the following test suites:

DLT	The Diagnostic Link Tests (DLT) check the diagnostic link including the SRM's interface board, the USM, and the RS-422 cable.
NST	The Node Stand-alone Tests (NST) check the Node Confidence Test (NCT) results, extended RAM on the node boards, and the node Direct-Connect® modules (DCM), and .
HLT	The Host Link Tests (HLT) check the DCM link including the System Resource Manager's DCM module, part of Cabinet 0's DCM buffer board, Node 0's DCM module, and the ability of these boards to communicate with the host.
IOLT	The I/O Link Tests (IOLT) check the DCM communication links between each compute node and I/O node.
NLT	The Node Link Tests (NLT) check the internode communication links and node DCM modules.
CLT	The Cube Link Tests (CLT) check the remaining parts of the cabinet's DCM buffer board and Node 0's DCM module that were not checked by HLT.
OHT	The Optional Hardware Tests check hardware boards such as the vector boards.

To run CDP, follow this procedure:

1. To invoke CDP you must be root and be in the */usr/ipsc/diag* directory or have that path defined in your shell path variable. Then type:

```
bootcube -D1-2
./cdp
```

2. The Main Menu will be displayed and you will be prompted to enter the number of the test you want to execute. If you select **Run Standard Tests**, the DLT, NST, HLT, NLT, CLT, and OHT tests will be run in that order using default values.
3. Error messages are displayed on the SRM monitor as they occur. If you receive an error message as a result of running CDP, call iSC Customer Support.

For more information on running CDP, refer to the *iPSC®/2 System Administrator's Guide*.

INTRODUCTION

The communications (comm) board in some previously installed system (consisting of optional compact cabinets) does not have any channel 7 connectors on it. If you are adding an I/O cabinet to a system of this kind, you need to replace one (or more) of the comm boards in this system. This appendix describes how to do this.

To install the new comm board, follow this procedure:

1. Open the back door of the cabinet in which you intend to install the new board, as described in Chapter 5.
2. Disconnect all cables from the existing comm board (the SRM cable with its 20-pin connector on the lower left corner of the board, one or more flat ribbon cables with 64-pin connectors going from the backplane to the top connectors on the comm board, and the 10-pin USM connector on the top left side).
3. Remove the two Phillips screws holding the backplane in, remove the board, and set it aside.
4. Align the holes in the new board over the screw holes in the backplane, and fasten it in place with the screws that previously held the old board.
5. Reconnect the cables you previously removed from the old board. The locations of the connectors on the new board are the same as on the old board.
6. Additional 60-pin flat ribbon cables are supplied with the new board. Connect all four of the connectors on the backplane to the four 60-pin connectors on the top of the comm board.
7. Connect the supplied 10-pin cables (part number 313818) to the channel 7 connectors that are in a row along the bottom of the comm board. Start with the left-most of these (Node 2), and proceed to the right (Node 6, 10, 14, 18, etc.) until all are installed.
8. If a new I/O panel is supplied, replace the I/O panel in the cabinet.
9. Connect the other end of each cable to the I/O panel with the hardware provided.
10. Install the I/O system as described in Chapter 5.